

CARVART®

# MANUAL OF INSTALLATION USE and MAINTENANCE

AURA ZIP

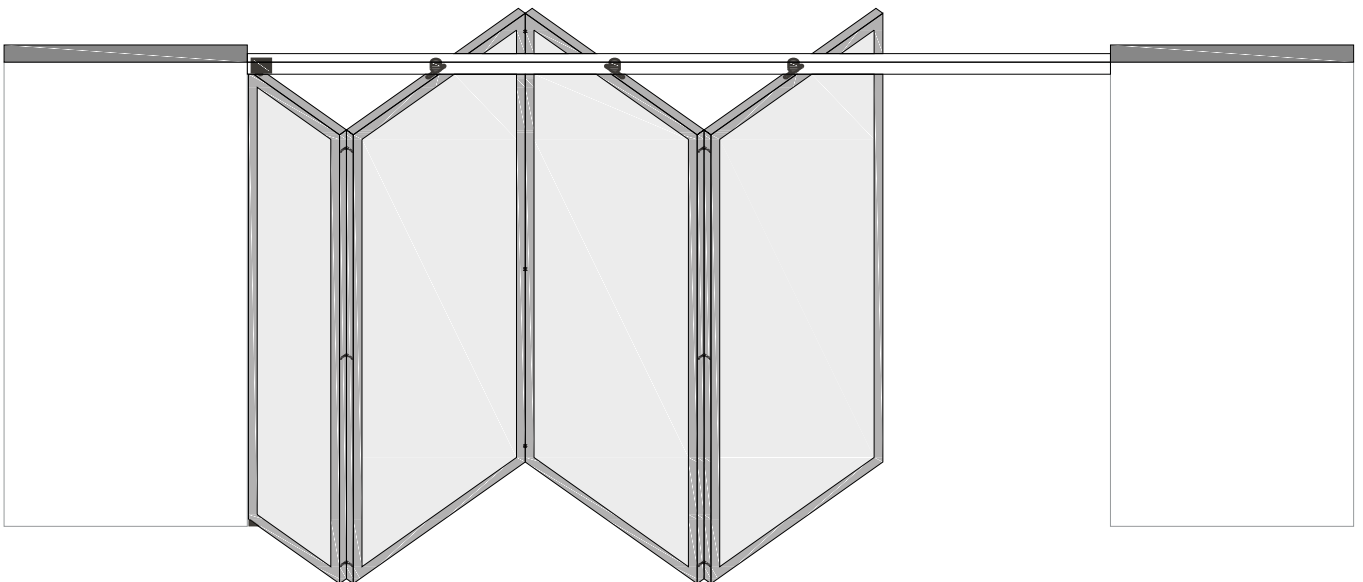

## TOOLS NEEDED FOR ASSEMBLY

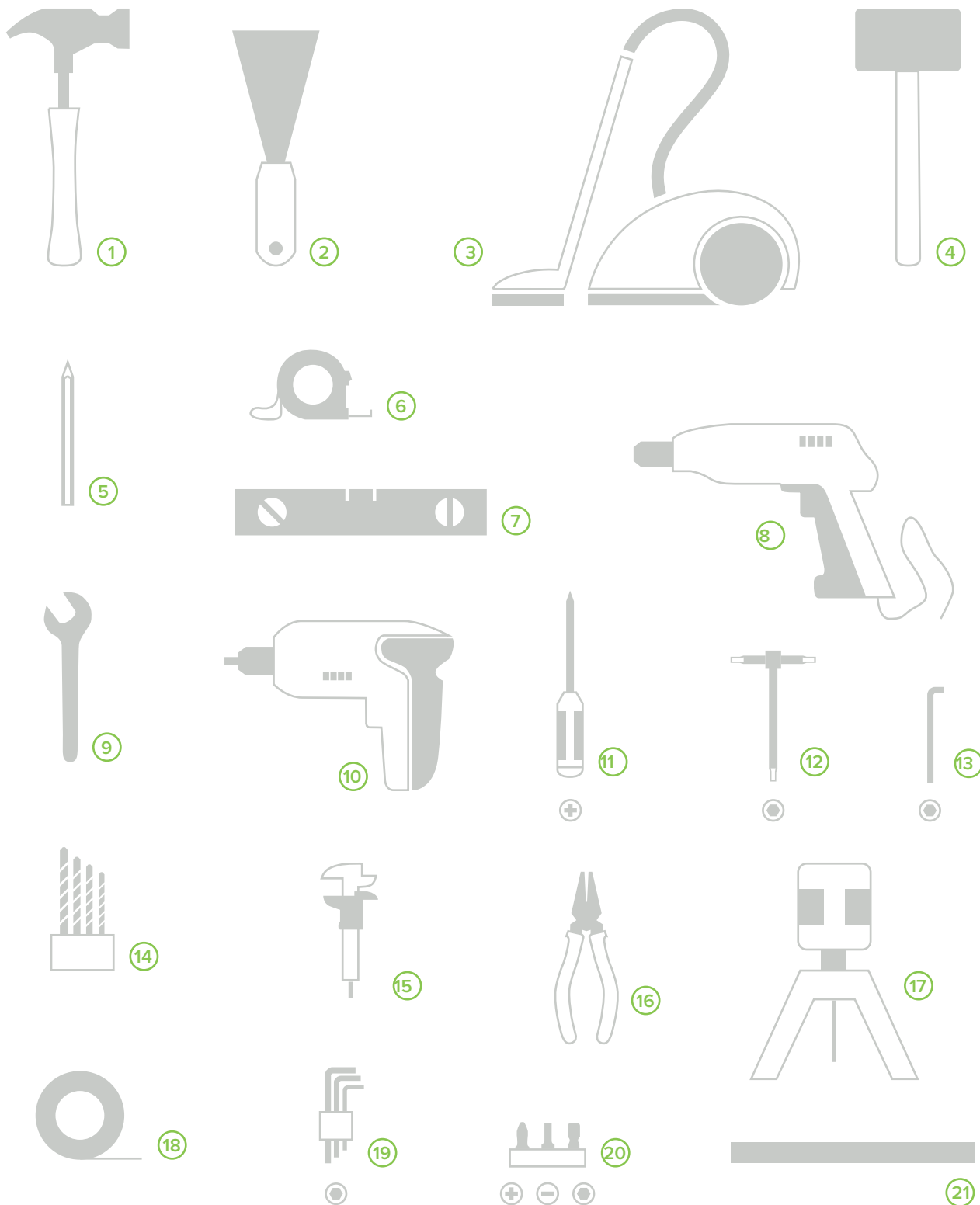









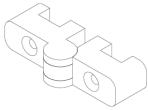
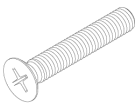

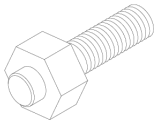
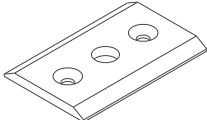
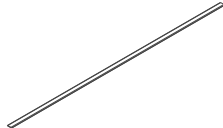
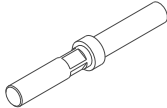
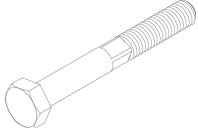
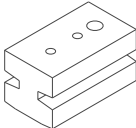

1. Hammer
2. Putty Knife
3. Vacuum cleaner
4. Hard rubber hammer
5. Pencil
6. 5-meter tape measure
7. Level

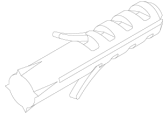
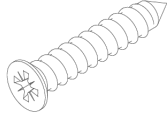
8. Impact drill
9. Adjustable Wrench
10. Screwdriver
11. Phillips screwdriver
12. 5mm Hex Wrench
13. 3mm Angled Hex Wrench
14. Set of drill bits for drilling floor

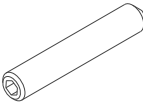
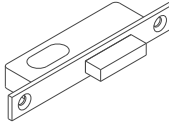
15. Caliper
16. Needle Nose Pliers
17. Laser Level
18. Tape
19. Hex wrench set
20. Set of screwdriver bits
21. MDF for hinges (L=110 cm)

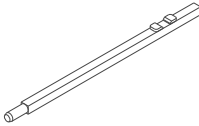
## COMPONENT BOARD

<p>COD. 400008 (burnished) COD. 400008.1 (niploy)</p>	<p>COD. 01702.05030 (burnished) COD. 01702.5030I (inox)</p>		<p>COD. 009010.201</p>
		<p>VSTEL grain M4x25mm conical tip</p>	
<p>Aurea Zip hinge burnished black or niploy</p>	<p>TPSEI screw M5x30mm burnished or stainless steel</p>		<p>Hinge thickness 6x12x0,1 mm</p>
<p>COD. 009010.202</p>	<p>COD. 400008C</p>	<p>COD. 400013.2</p>	<p>COD. 400015</p>
			
<p>Hinge thickness 6x12x0,2 mm</p>	<p>Calibrated hinge pin Ø4x16</p>	<p>Floor pin Aurea Zip D=24xH=60 black burnished</p>	<p>Chamfered floor plate 62x54x4mm burnished</p>
<p>COD. 400014.01</p>	<p>COD. 400023</p>		<p>COD. 400012</p>
		<p>Beveled threshold 3130x54x4 mm</p>	
<p>Upper hinge pin D=100mm black galv. for initial module</p>	<p>Bogie pin standard module 41 mm</p>		<p>Upper pin retainer 39x41x72mm PVC black</p>
<p>COD. 02503.10</p>	<p>COD. 05106 (nera) COD. 05106.1032 (nichel)</p>	<p>COD. 04202.0636</p>	<p>COD. 01207.40045</p>
			
<p>Hex nut low M10</p>	<p>Recessed handle 75x32mm black or polished nickel finish</p>	<p>Plastic multi-purpose Zebra 6x35mm</p>	<p>TPS screw 4x45mm galvanized</p>
<p>COD. 03801.04008</p>	<p>COD. 03801.06050</p>	<p>COD. 163024</p>	<p>COD. 163043</p>
			
<p>VSTEL grain M4x8mm conical tip DIN 914</p>	<p>ISO4027 grain 45H (GR) EI3 M6x50mm conical tips</p>	<p>Lock for sliding doors</p>	<p>Cylinder for lock</p>
<p>COD. 440000</p>	<p>COD. 164010.02</p>	<p>COD. 03101.2910</p>	
			
<p>Ground pivot L=900 mm</p>	<p>Trolley Ø40mm</p>	<p>Notched outer washer D=10.5mm (grower)</p>	

## INITIAL CHECK

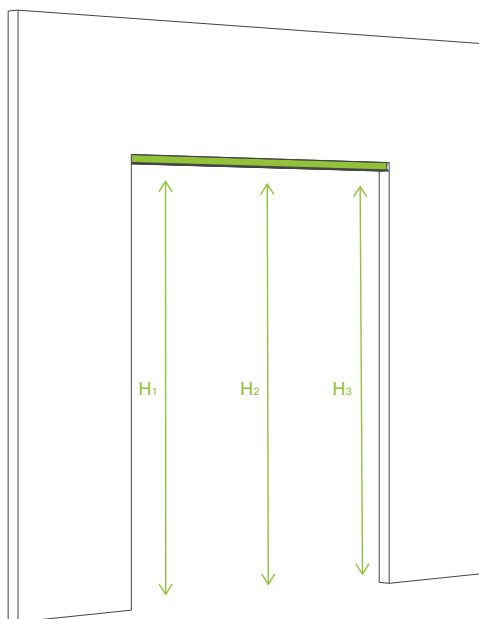

Measure height/width of the opening and check that correspond with the design dimensions.

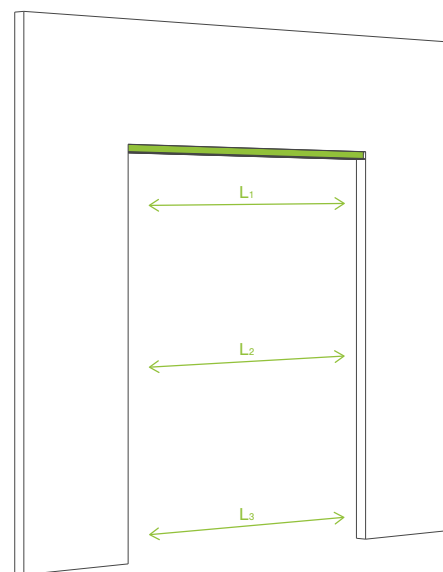

## OUT-OF-LEAD CONTROL

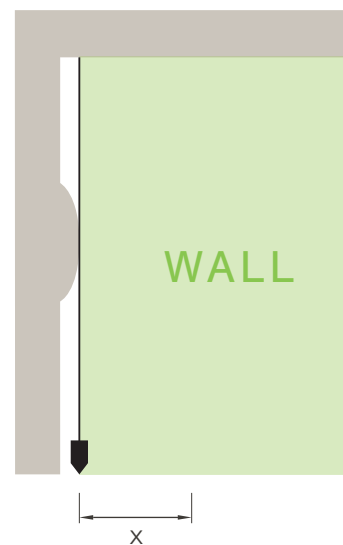
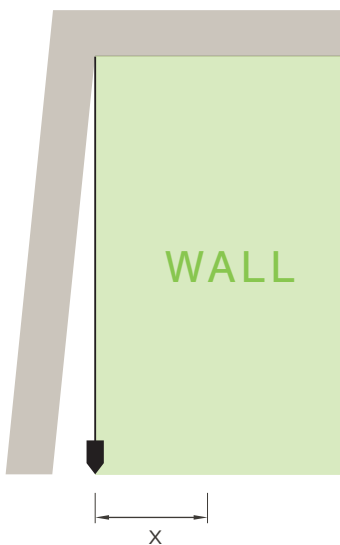
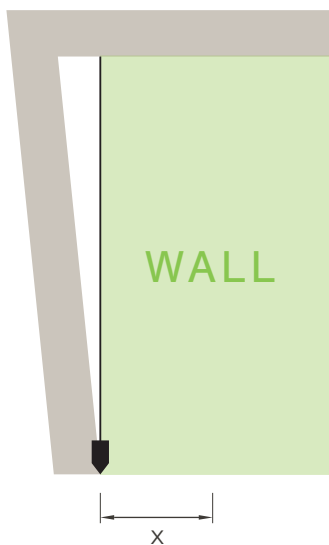
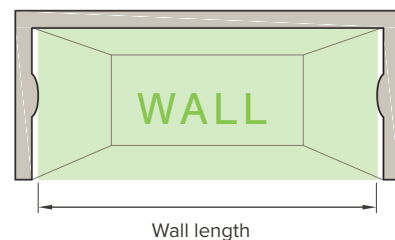
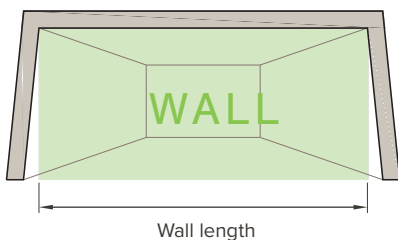
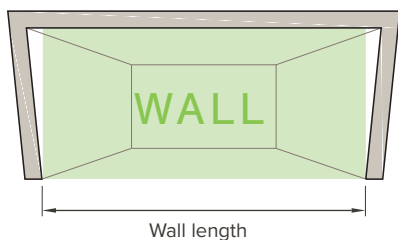

X = distance of the floor plate from the lead (SEE PAGE 7)

### TYPE OF MODULES

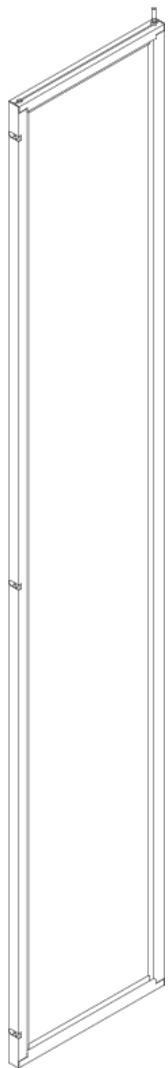

#### HALF MODULE

Ground and upper pin module, hinge slots on one side only

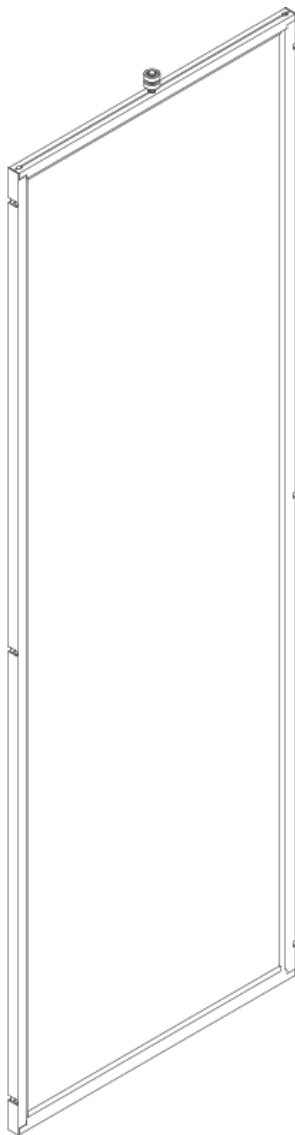

#### STANDARD MODULE

Module with upper trolley, hinge slots on both sides.

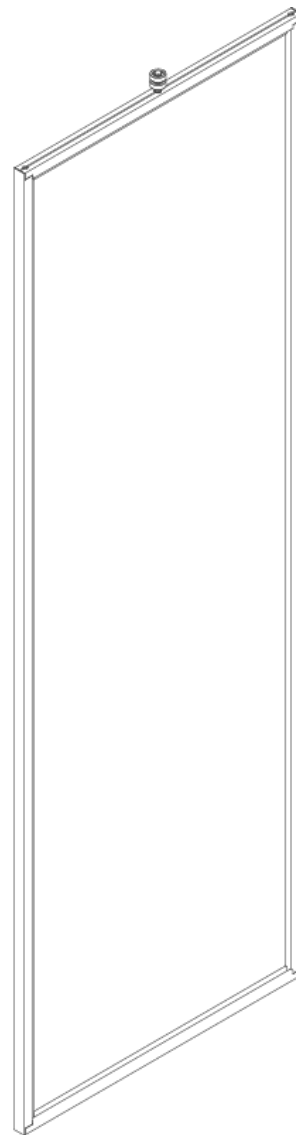

#### FINAL MODULE

Module with upper trolley, hinge slots on one side only.

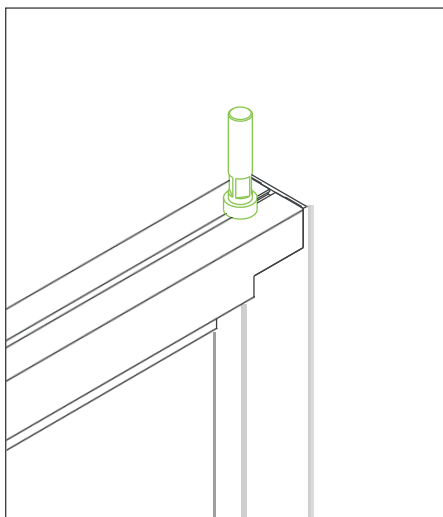

TOP PIN

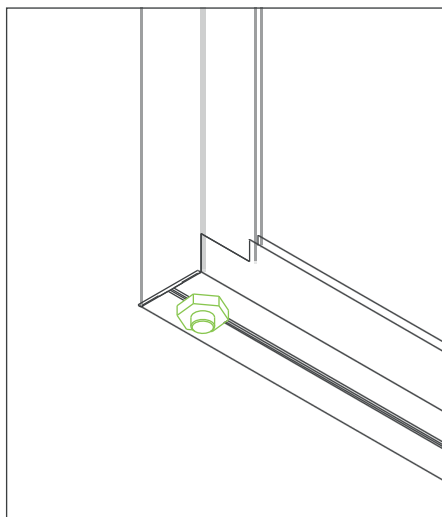

GROUND PIN

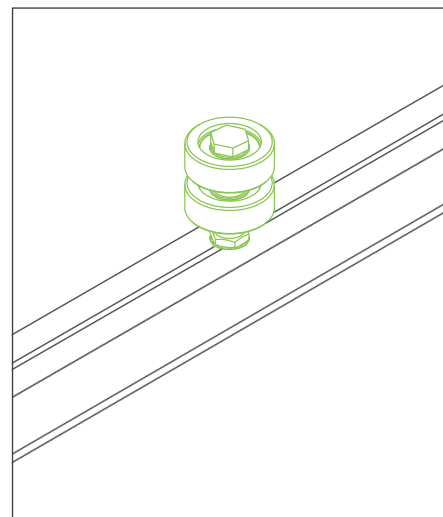

TROLLEY Ø40 mm

## RAIL CHECK AND REMOVAL OF THE DEMOUNTABLE PIECE

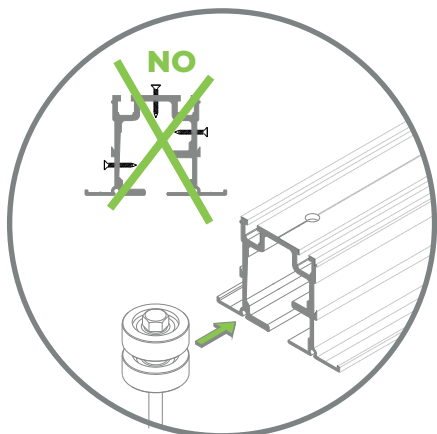

Check that the rail is clean, undamaged and/or obstructed

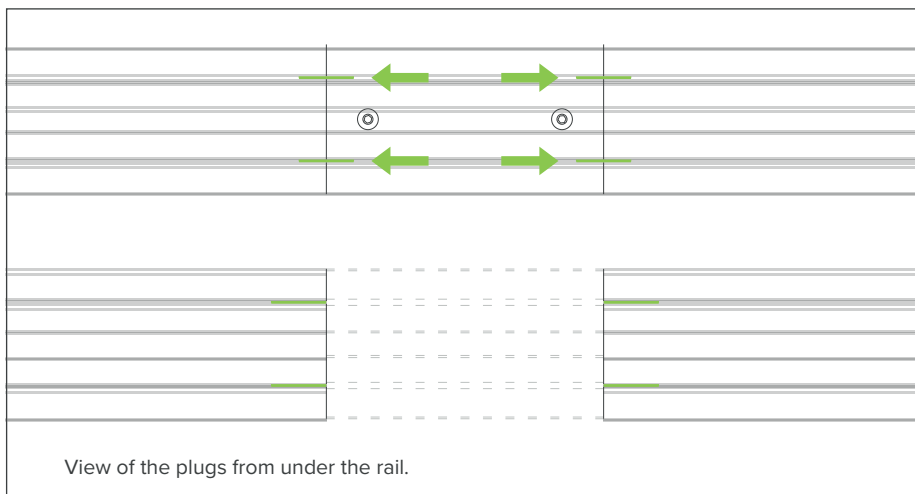

View of the plugs from under the rail.

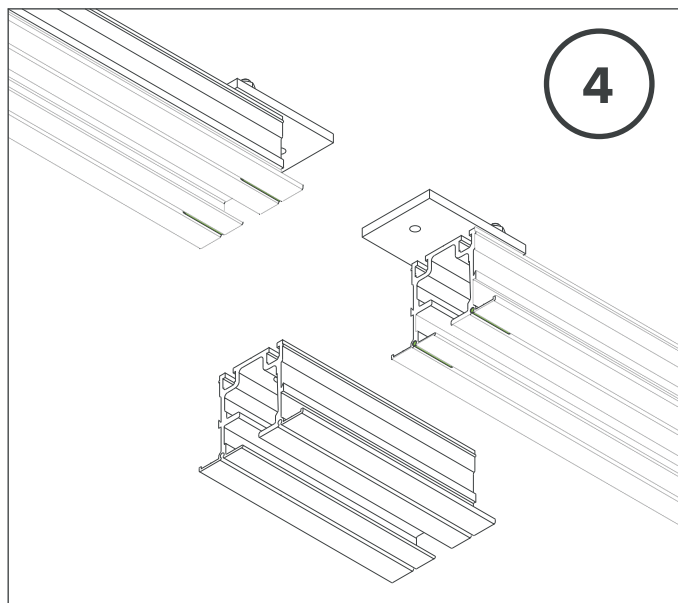
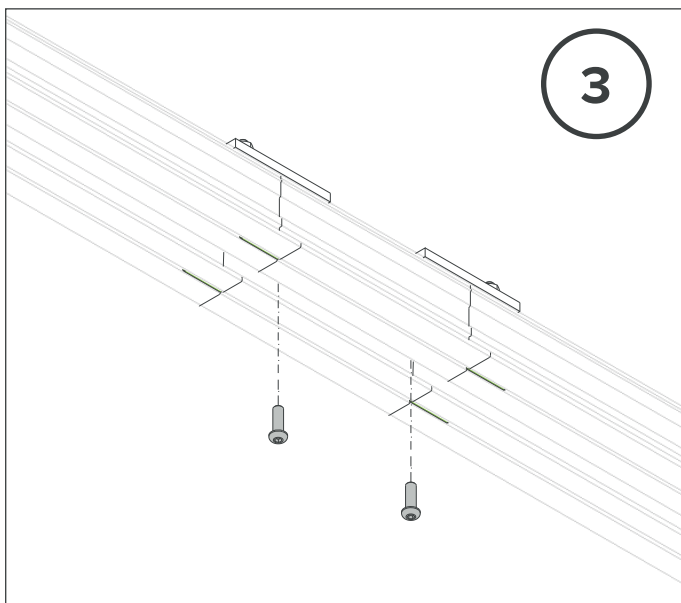
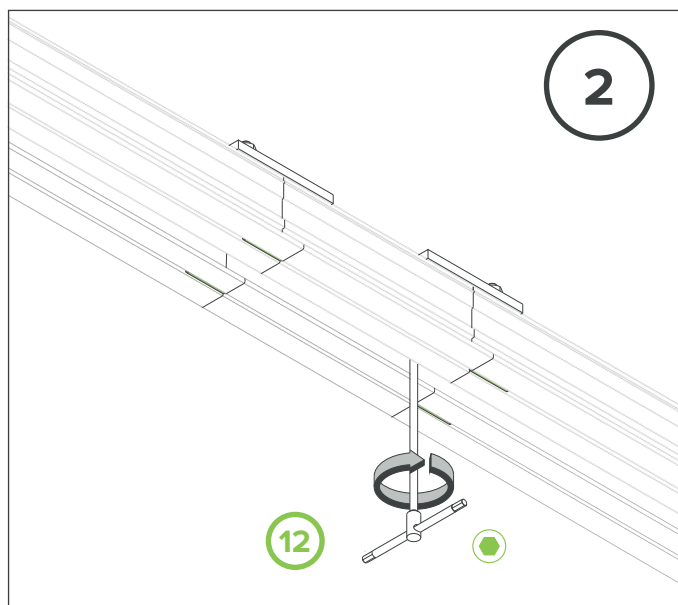
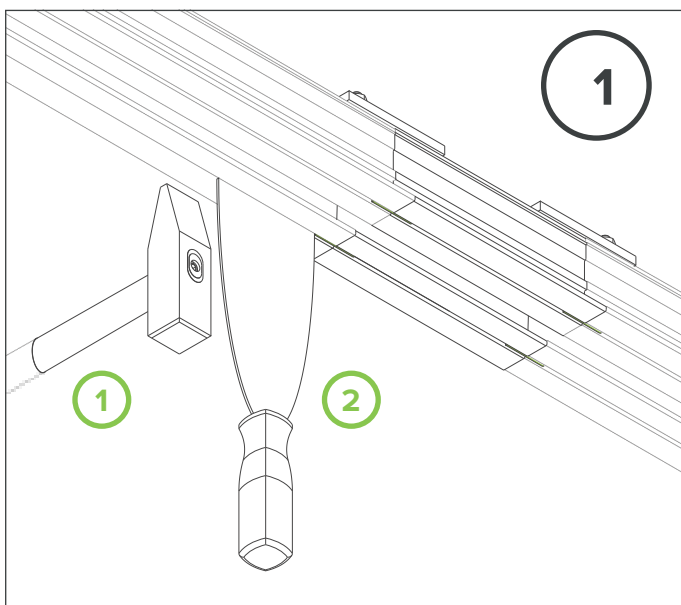

## GROUND PLATE FIXING

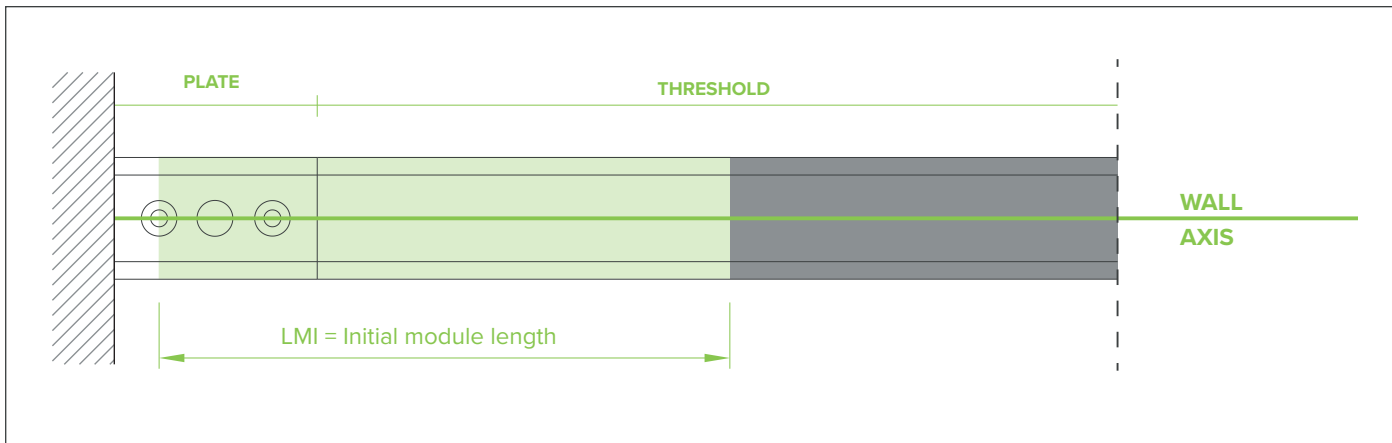

X 1

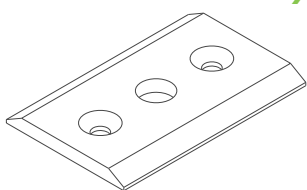

COD.  
400015

HARDWARE USED

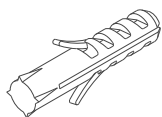

X 2

COD.  
04202.0636

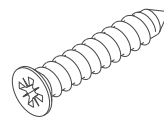

X 2

COD.  
01207.40045

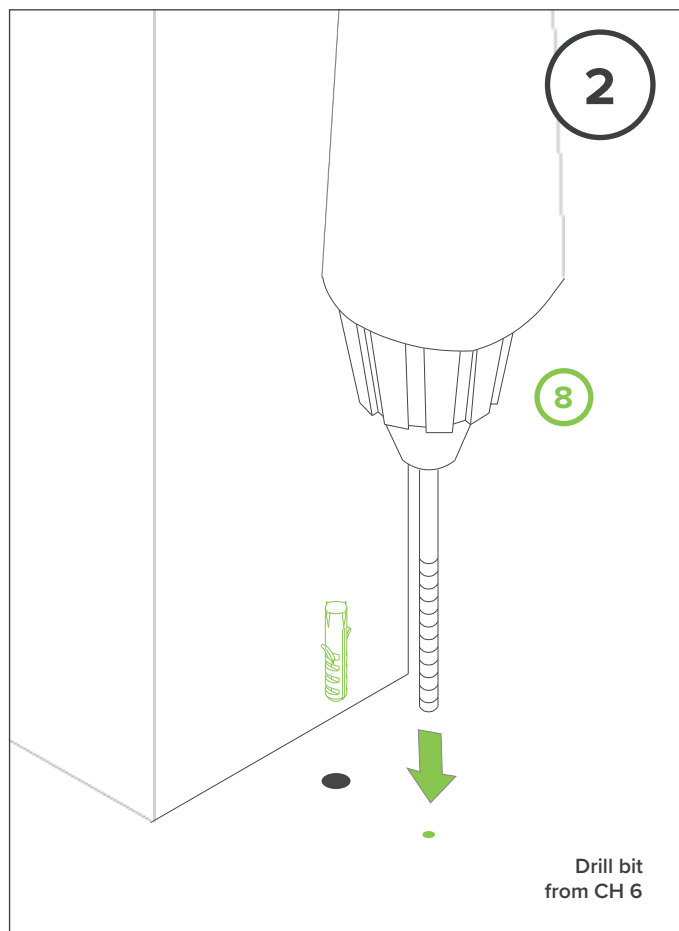
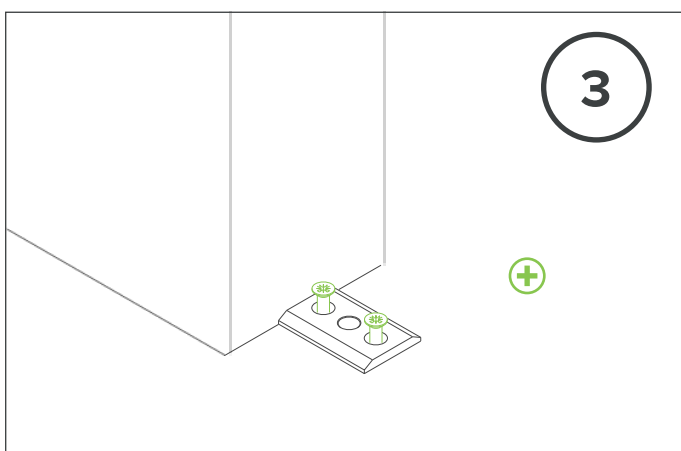
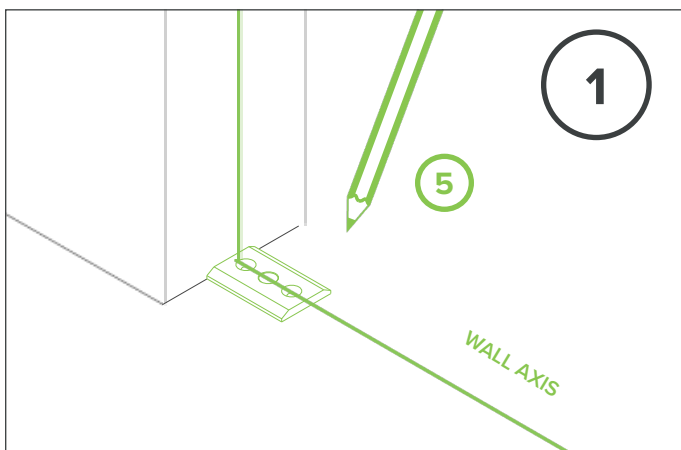

Drill bit  
from CH 6

!!! WARNING !!! If underfloor heating present  
evaluate depth for holes

# HALF MODULE ASSEMBLY

Insert both beads before mounting the half module.

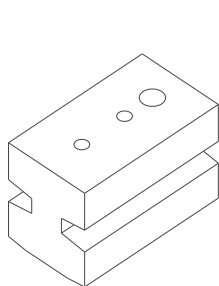

X 1

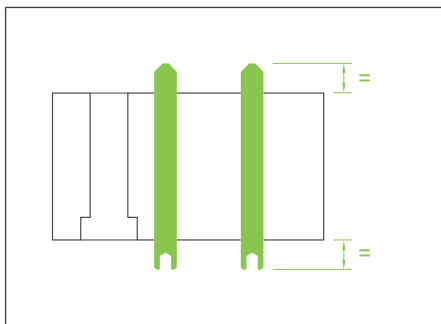

HARDWARE USED

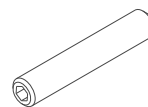

X 2

COD.  
400012

COD.  
03801.06050

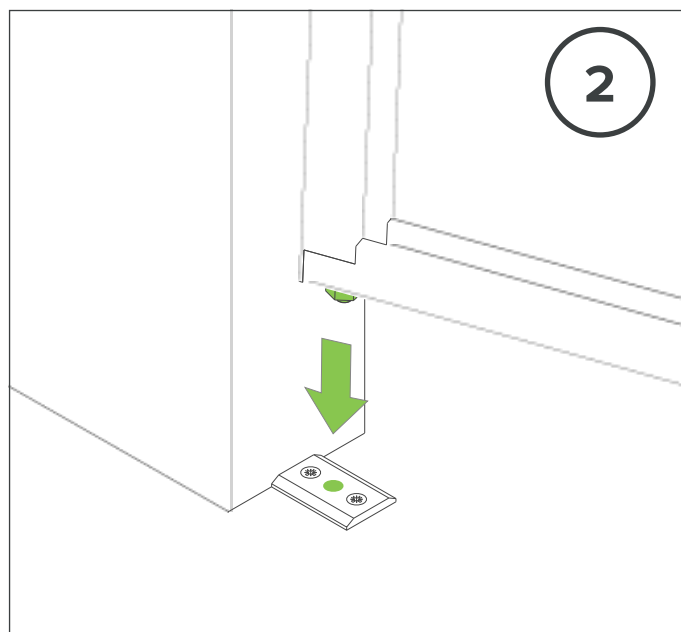
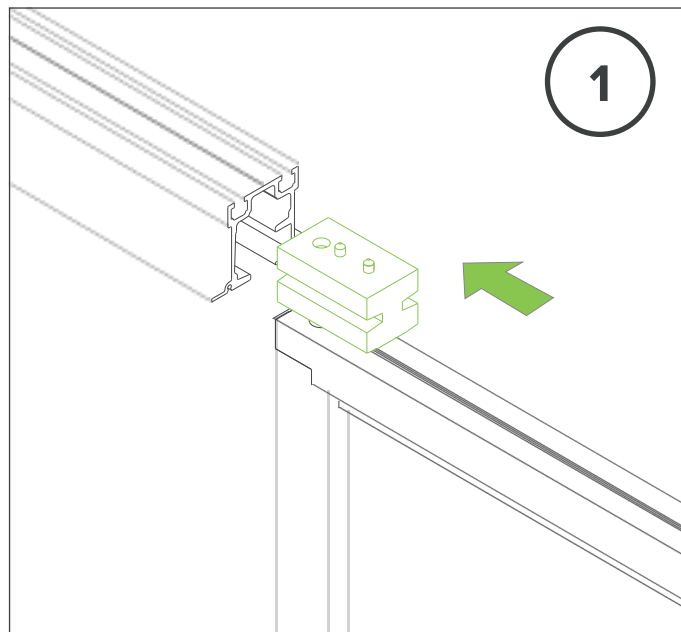
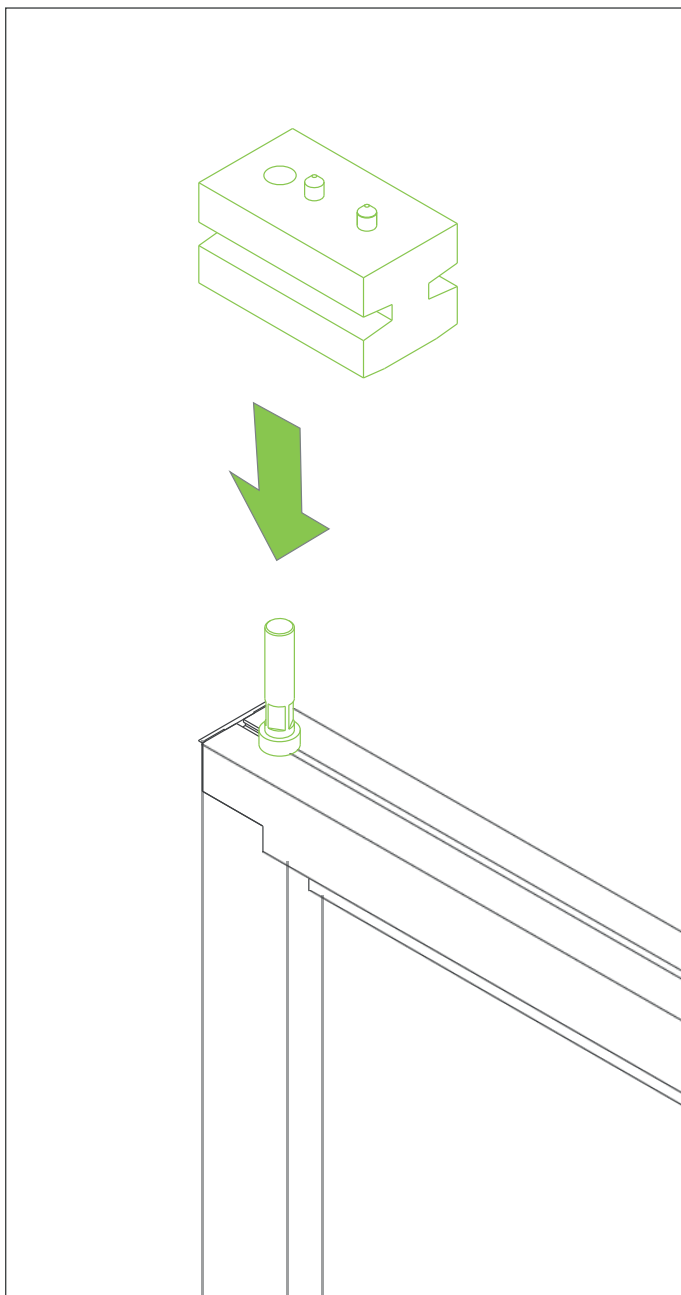



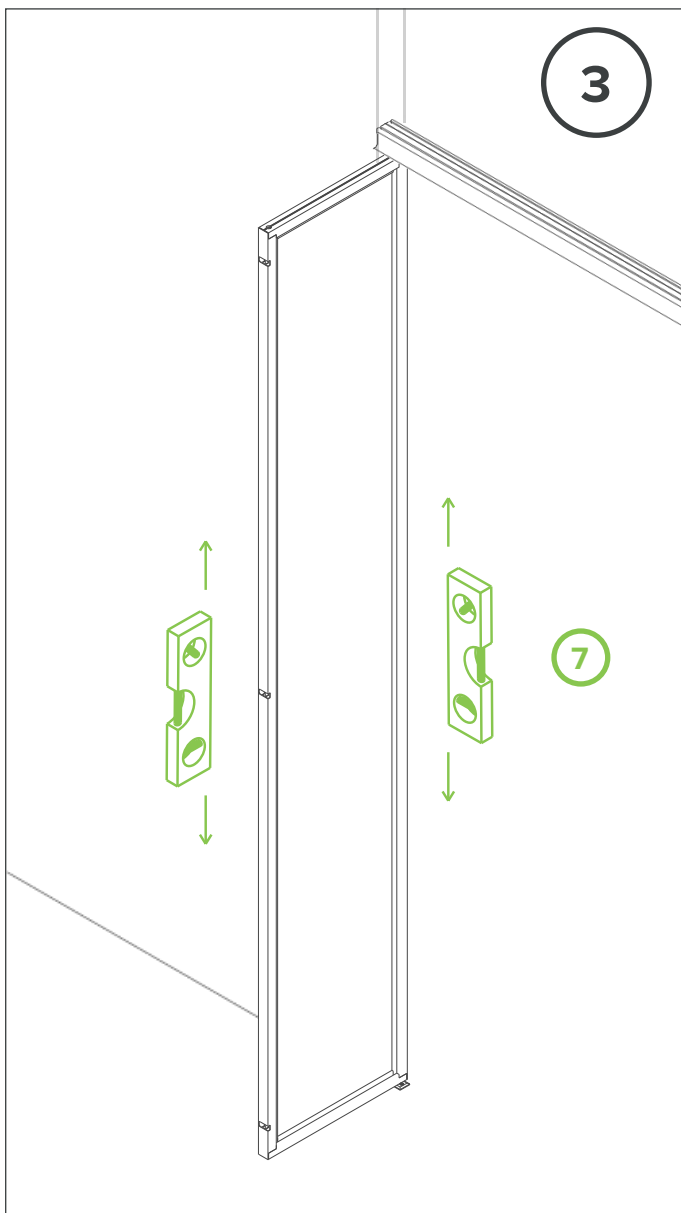

The module must be plumb on both axes in both cases before attaching the block.

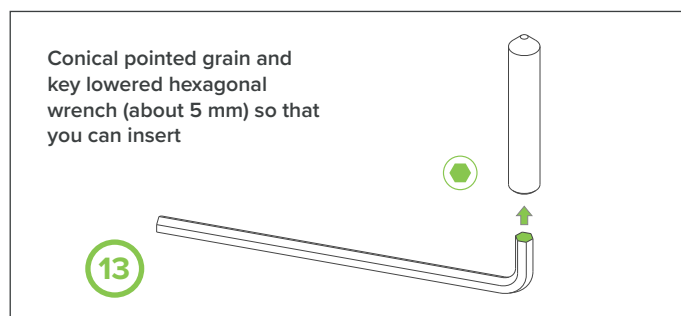
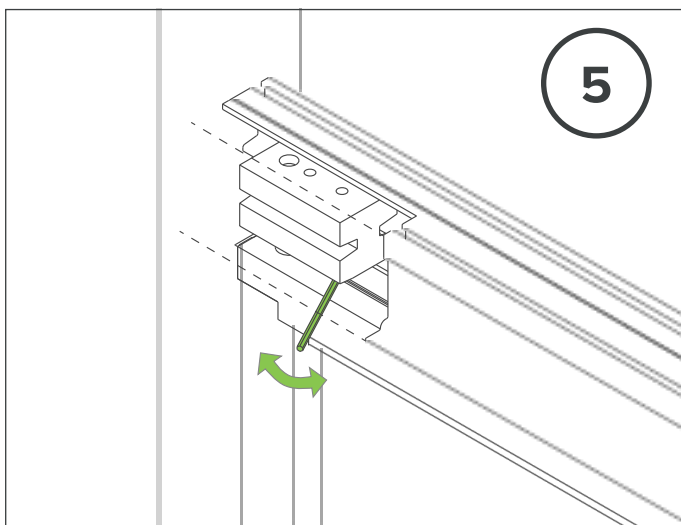

## INSERTION STANDARD AND SUBSEQUENT FORMS

Before inserting the modules remember to protect the floor.

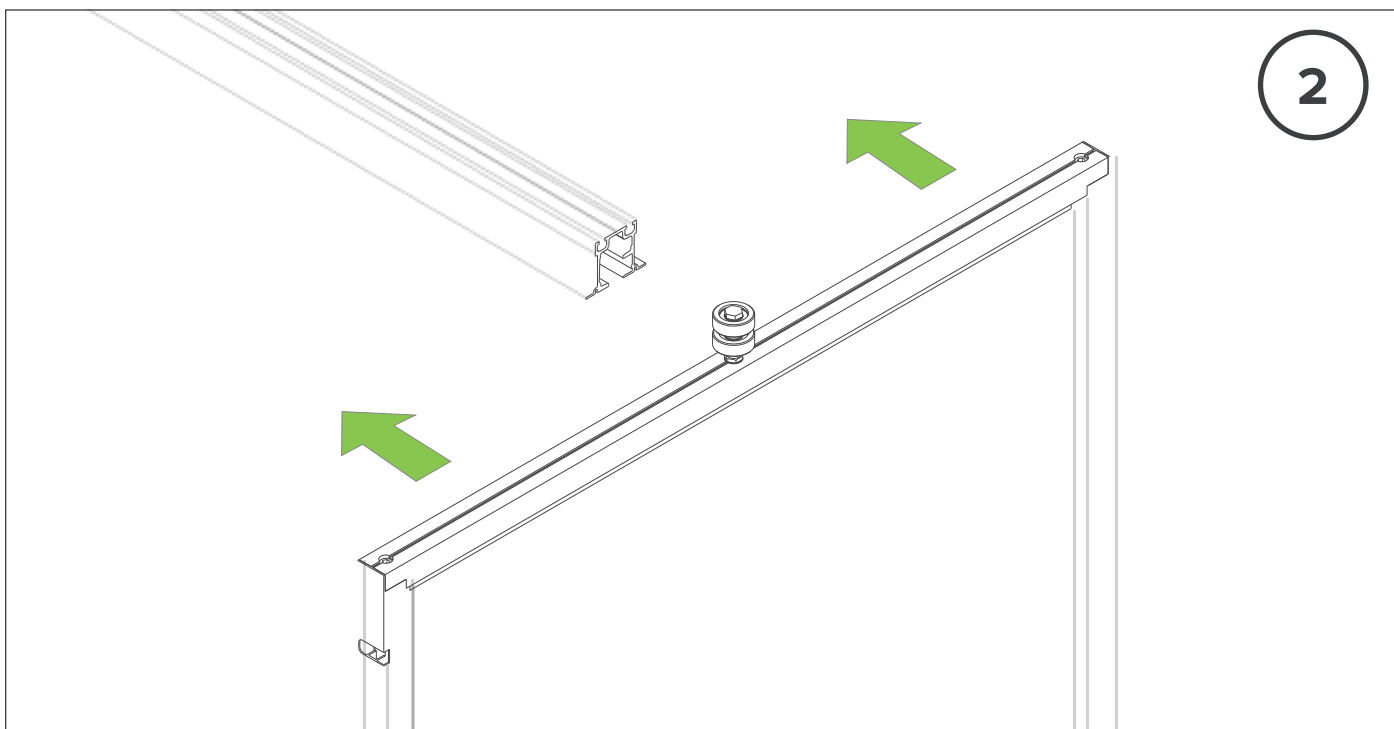
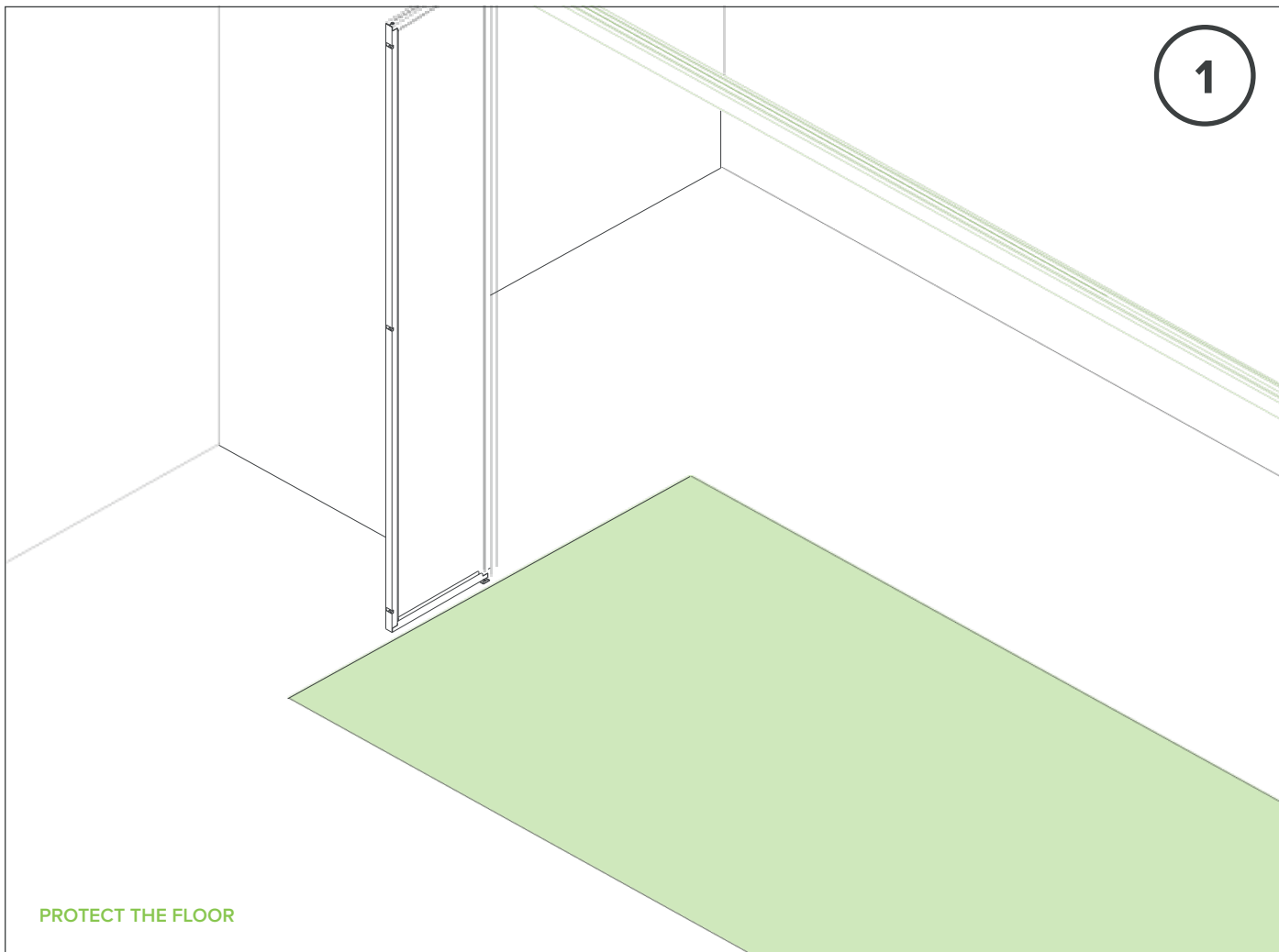

2



Check the correct order of entry on the project and from the numbers on the forms

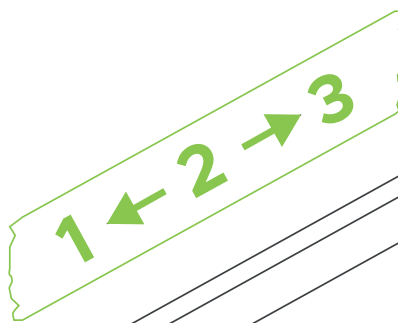
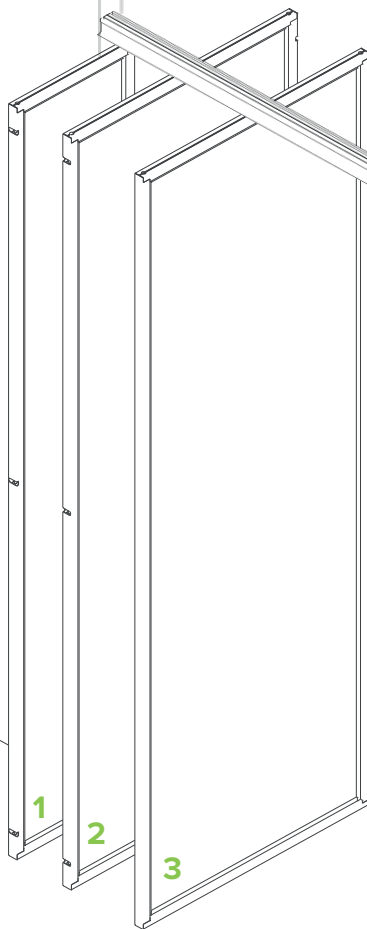
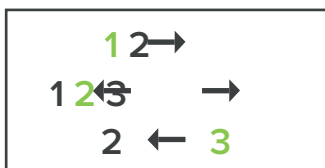

LABEL PRESENT AT THE BOTTOM OF THE INDIVIDUAL MODULES

### REPOSITION THE DEMOUNTABLE

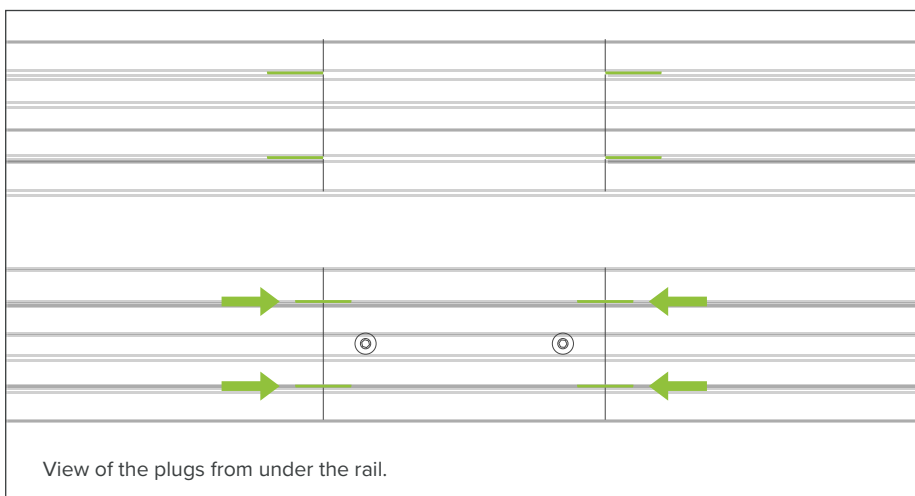
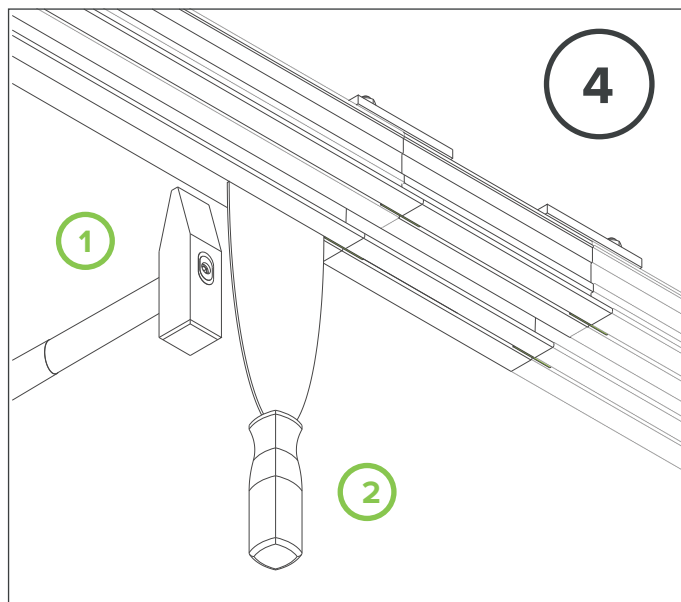
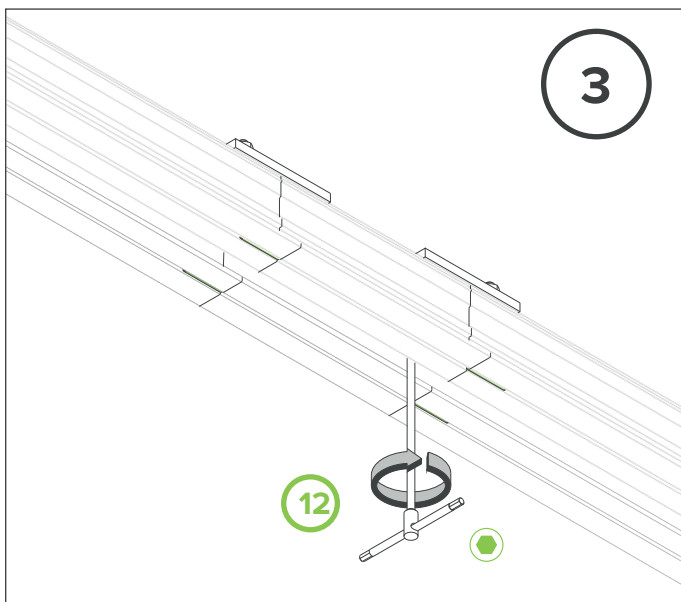
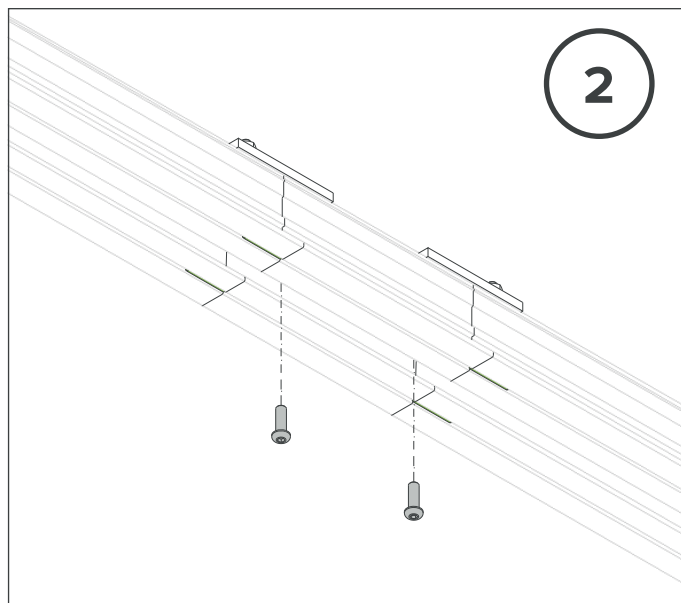
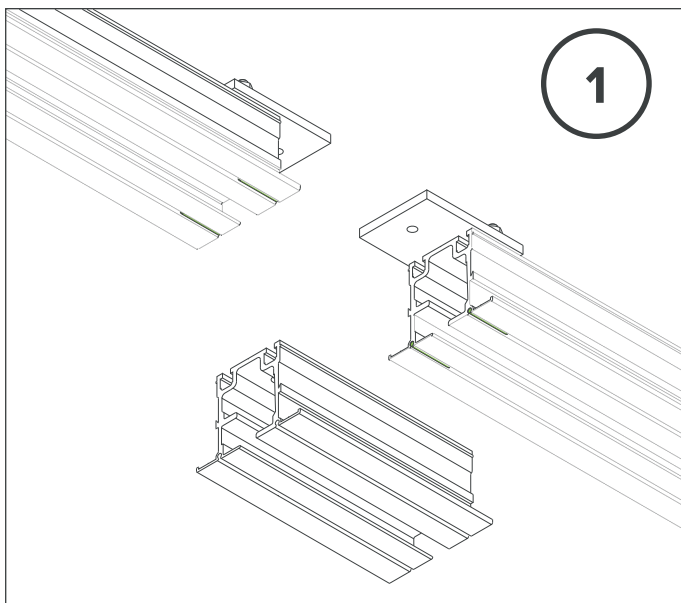

## POSITION OF TROLLEYS AND HINGE SLOTS

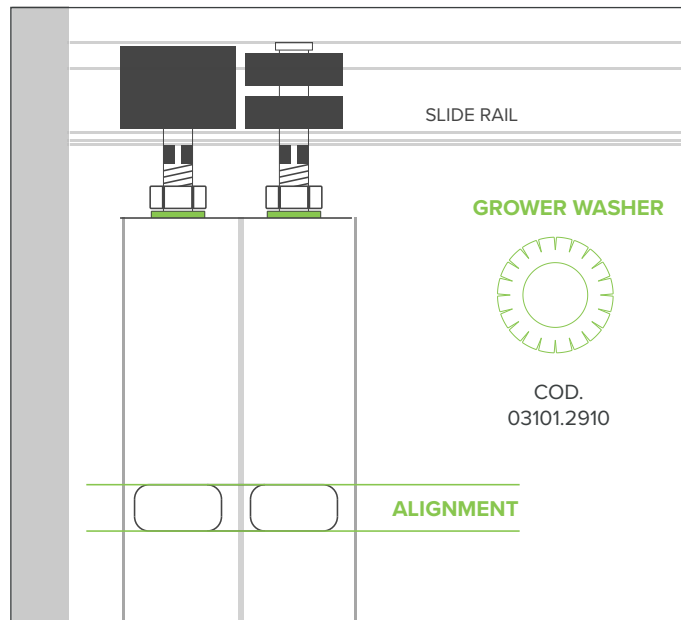
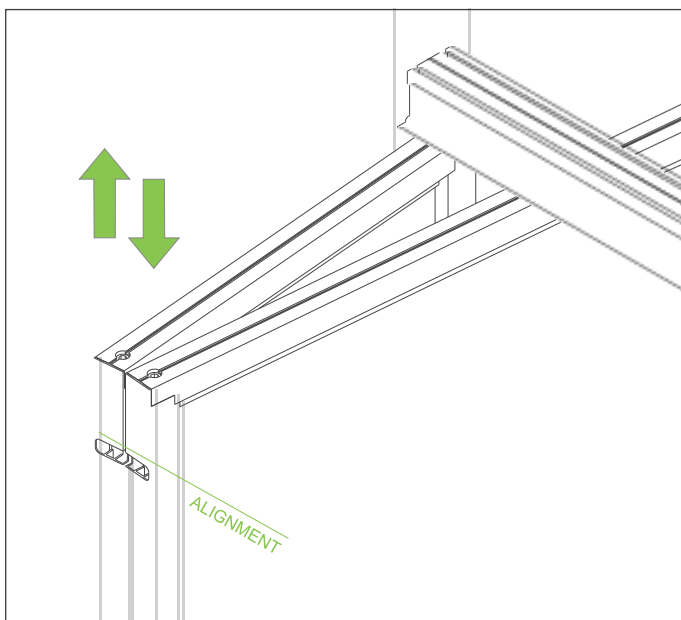
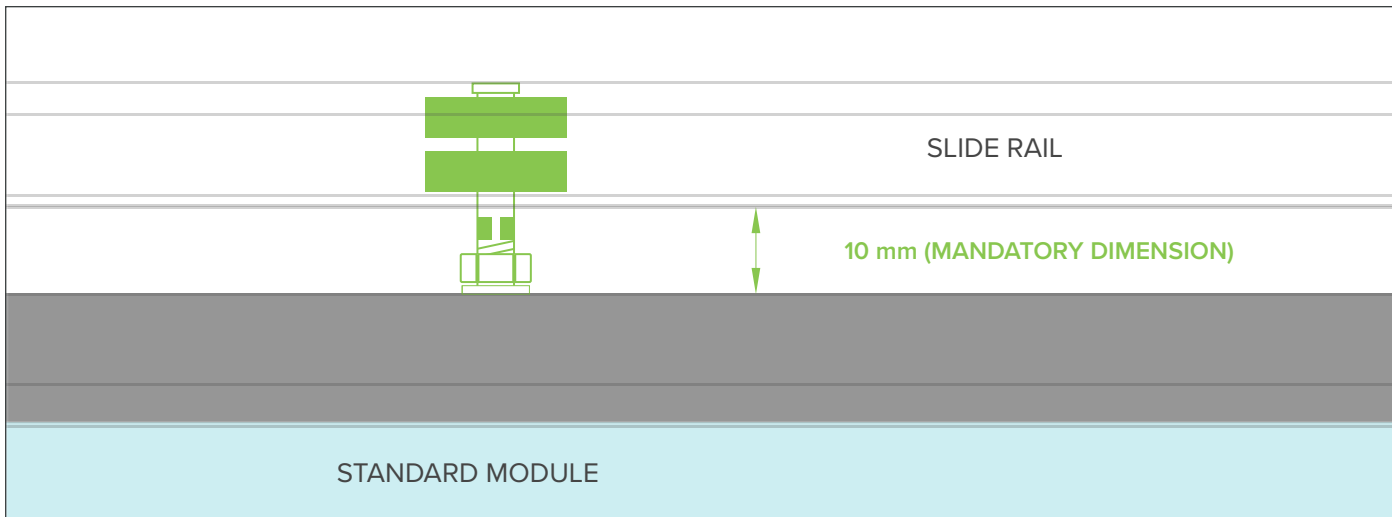

## TO ADJUST THE TROLLEY (if necessary)

Remove the carriage locking screw before adjusting.

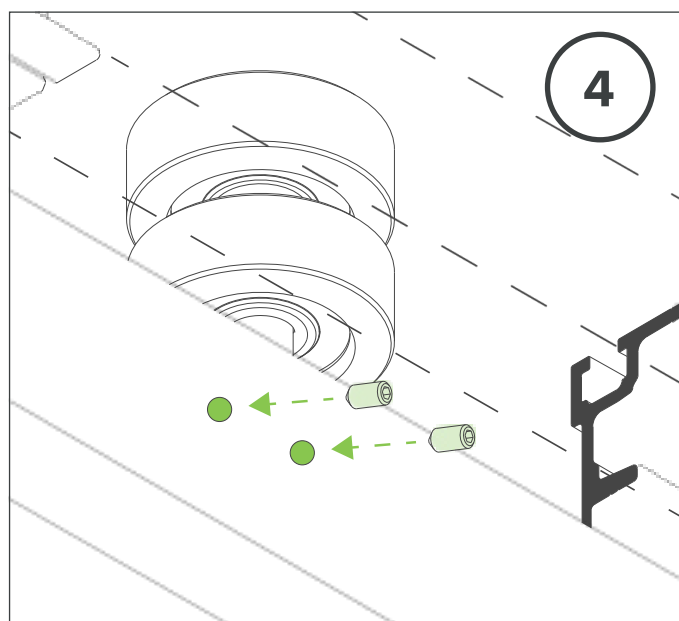
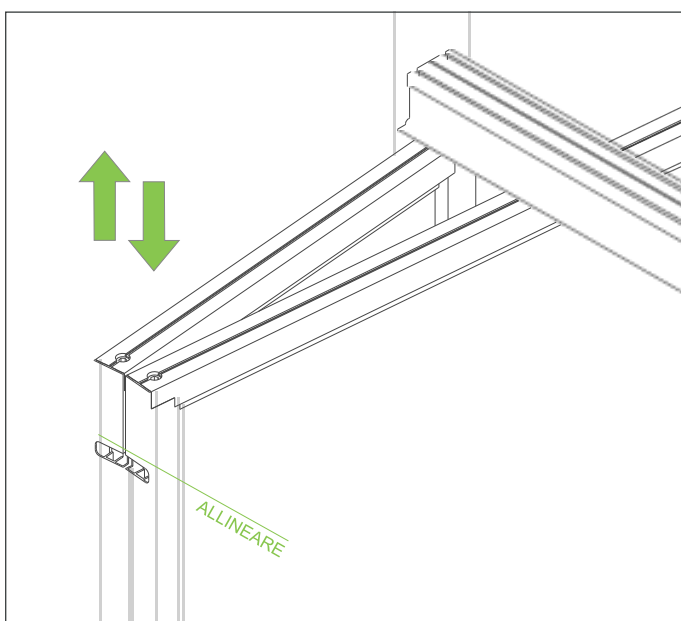
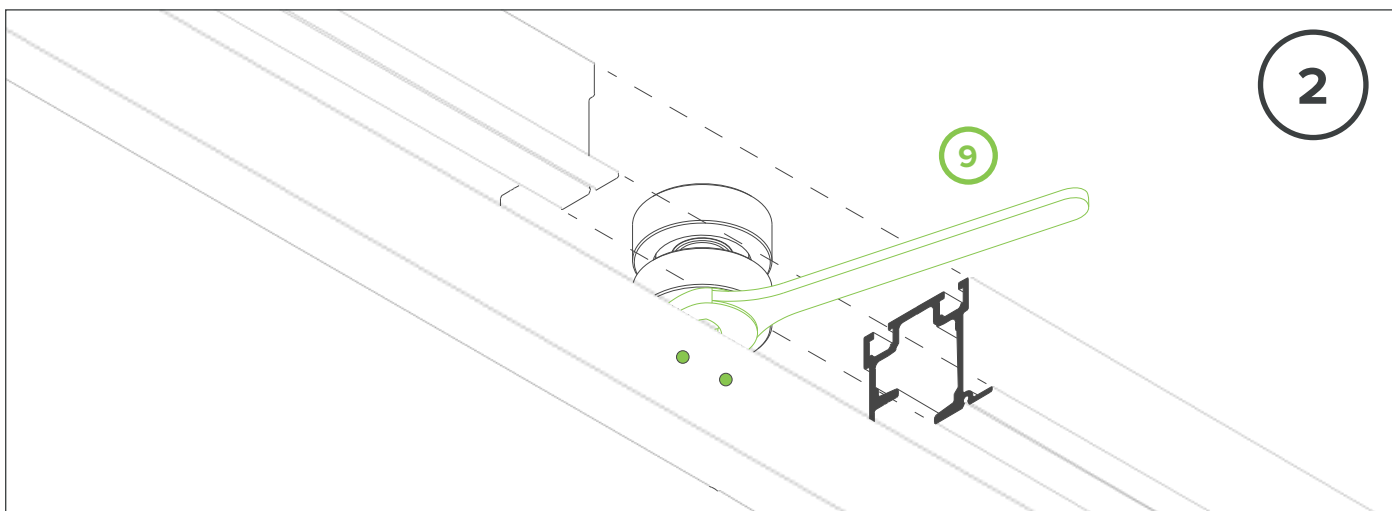
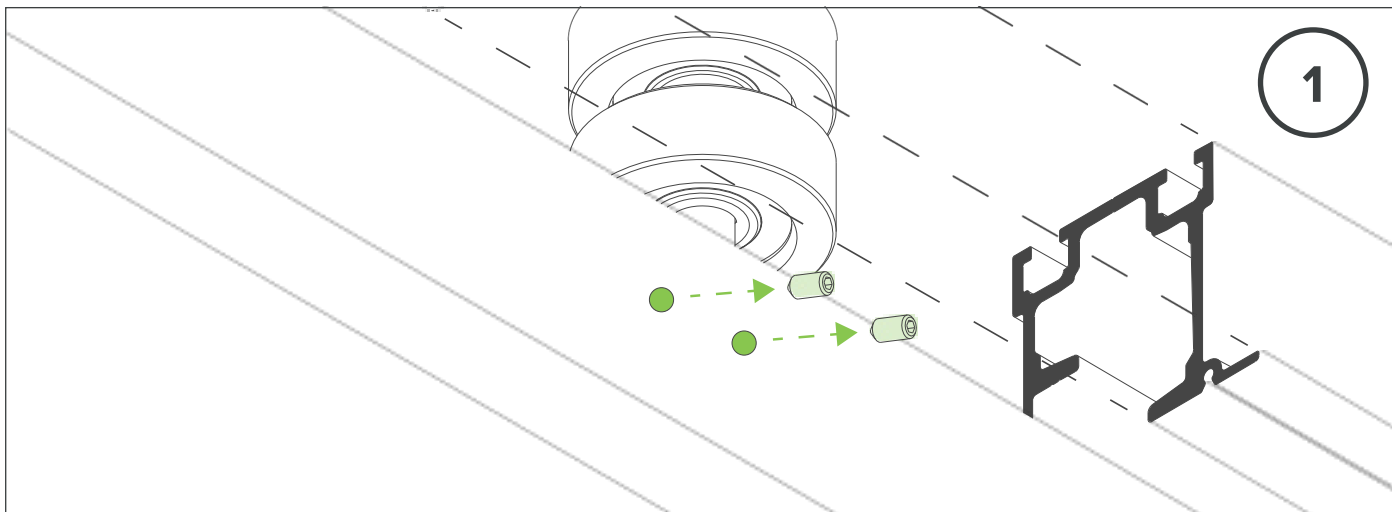

## ASSEMBLY OF HINGES

### HARDWARE USED

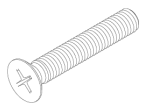

X 6

COD.  
01702.05030  
01702.5030I

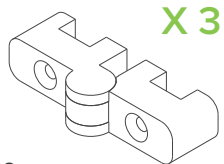

X 3

COD.  
400008  
400008.1

### CORRECT POSITION OF HINGES

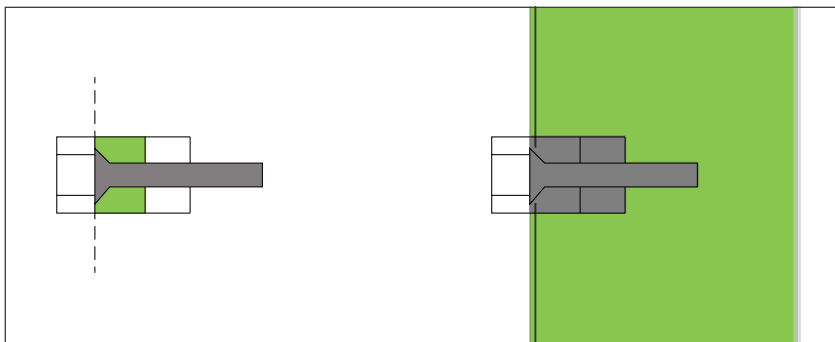
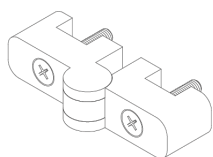

### IMPORTANT

THE SCREW MUST BE COPLANAR TO THE HINGE. THE  
HINGE MUST BE COPLANAR TO THE PROFILE.

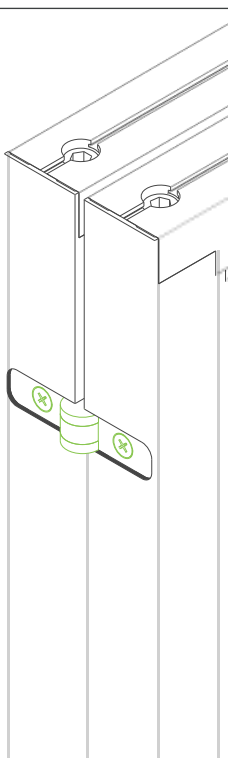

NO

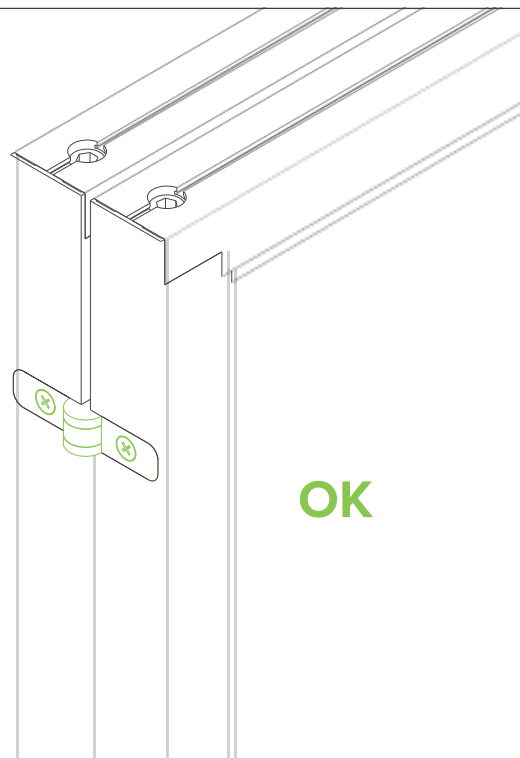

OK

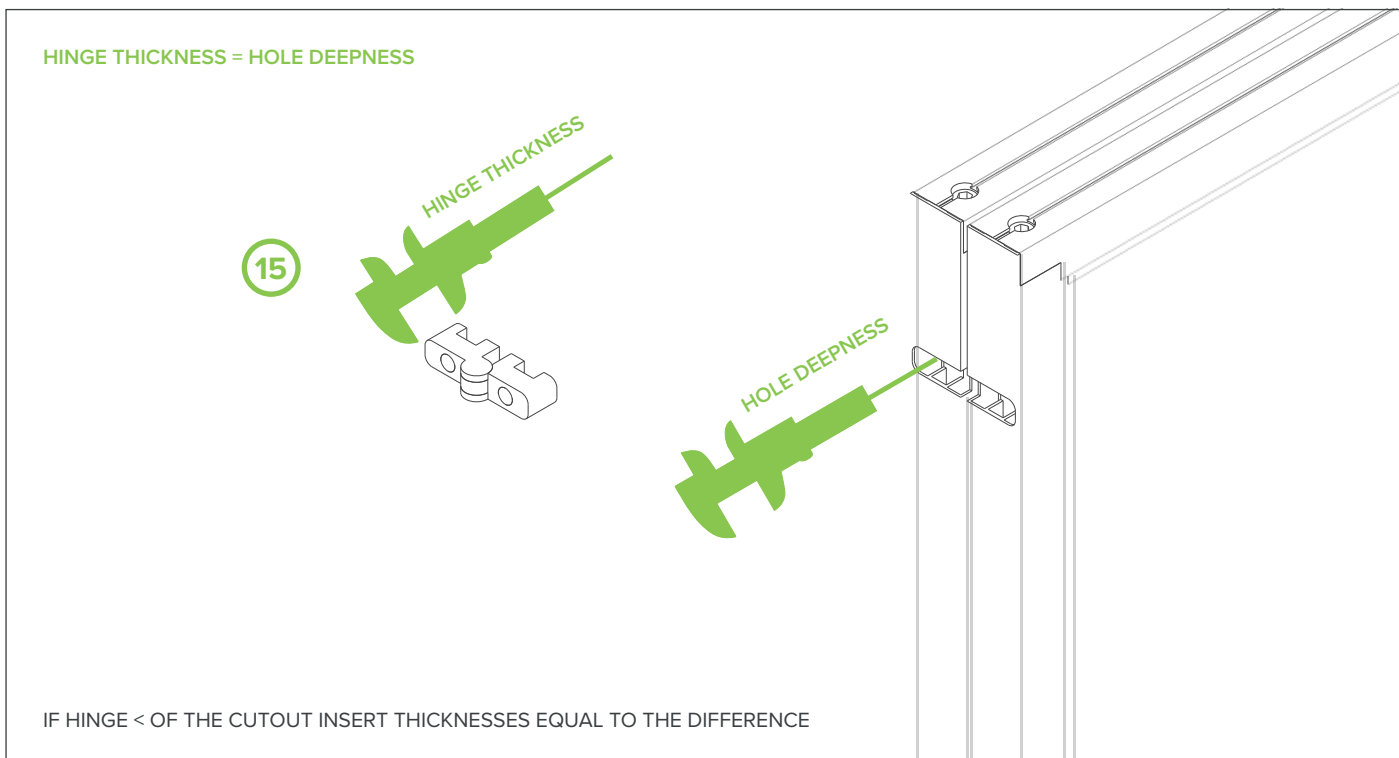
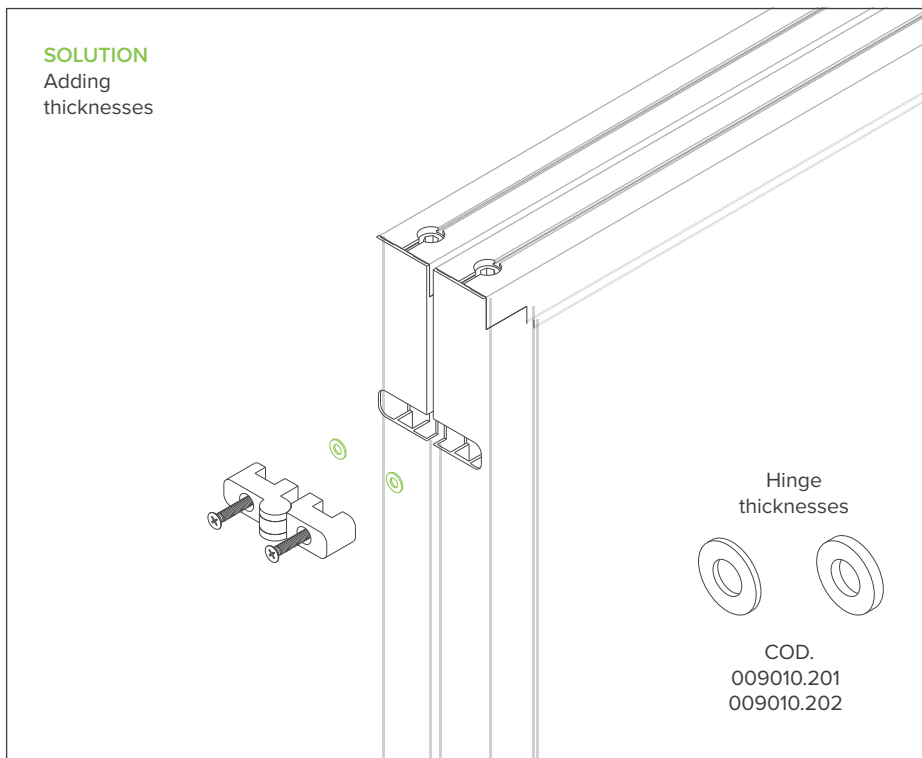
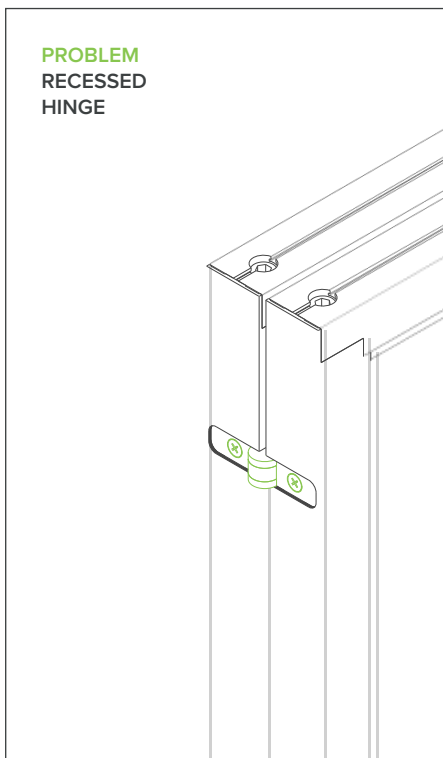



## CORRECT REMOVAL OF HINGES

How to remove hinges without ruining profiles.

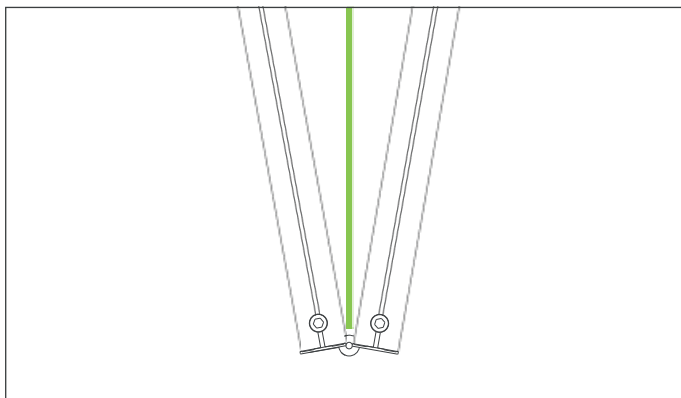

POSITION OF MODULES TOP VIEW

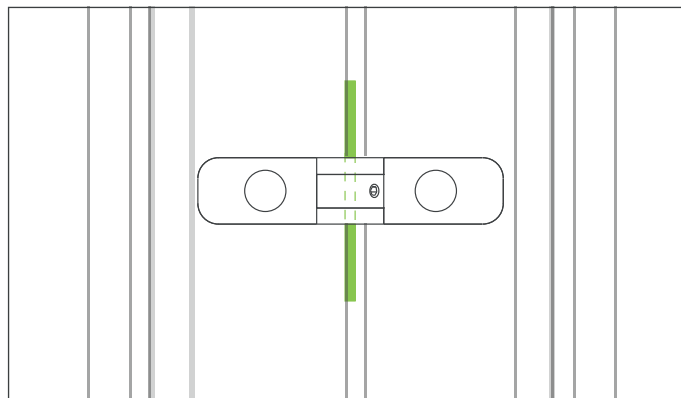

MDF POSITION FRONT VIEW

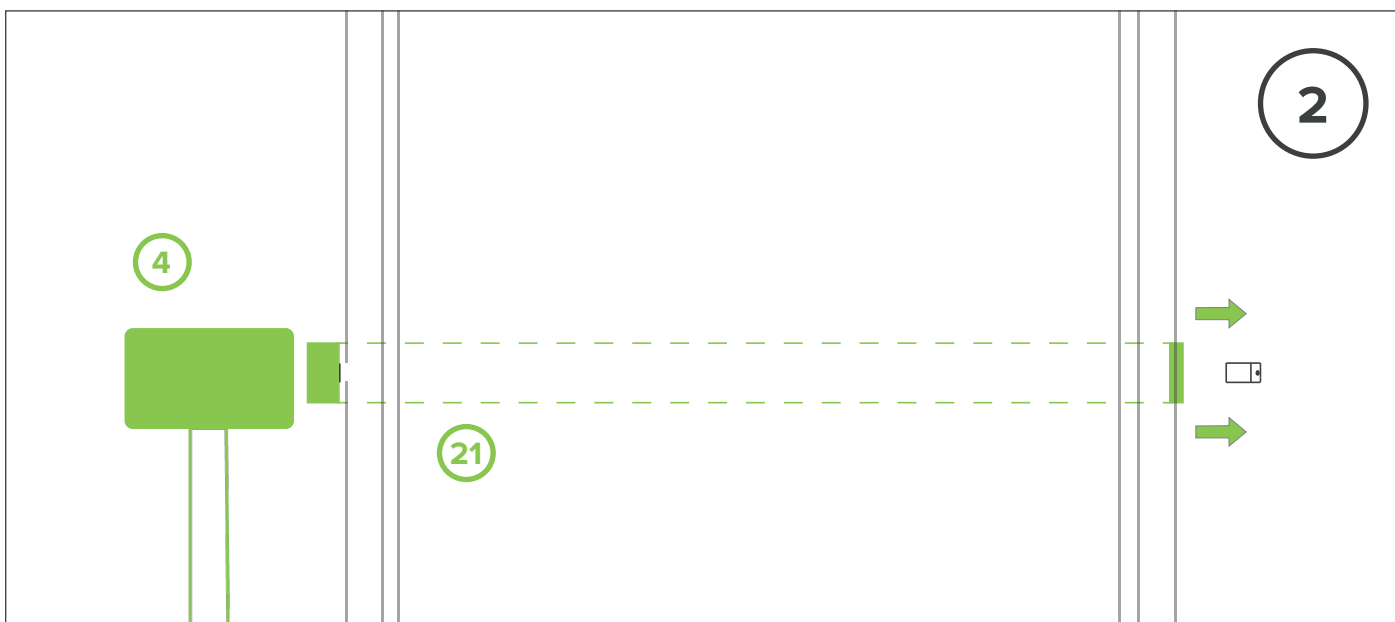
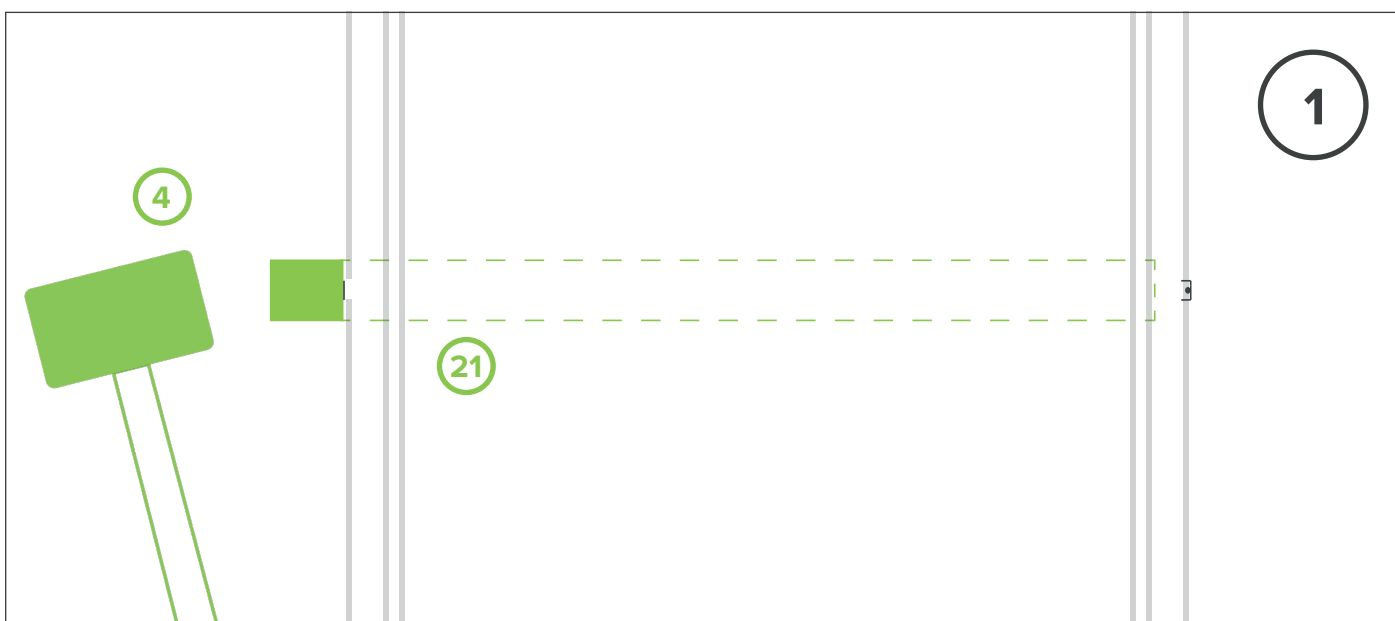

## TEST THE CORRECT FUNCTIONING

Once you have finished assembly, check the wall for proper wall distension.

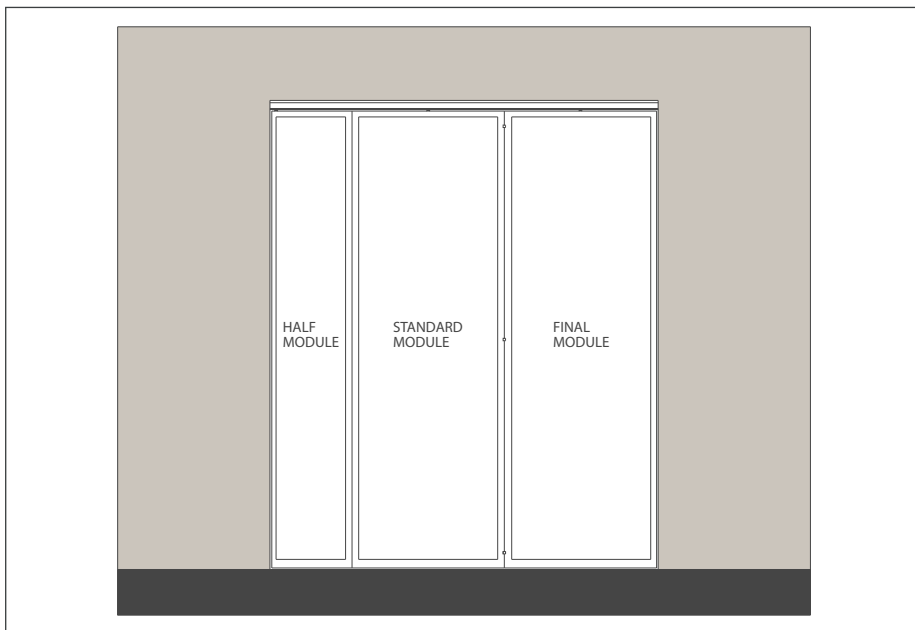

**WRONG** wall distension



**CORRECT** distension of the wall

If distension problems occur, check that the hinges are installed correctly. (SEE P. 14-15)

### CORRECT POSITION OF HINGES

#### IMPORTANT

the screw head must be perfectly flush with the hinge, the same goes for the hinge on the profile.

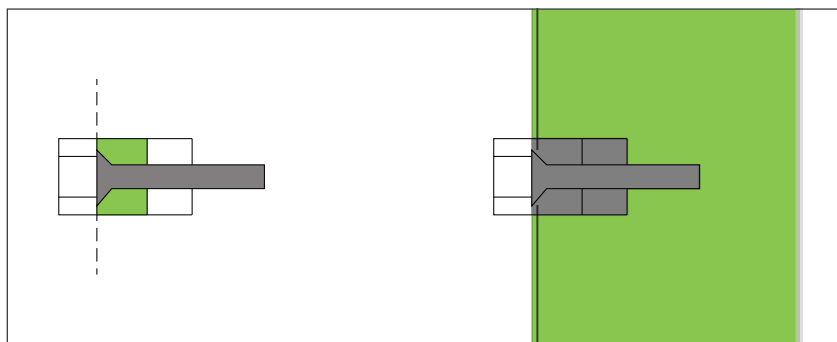
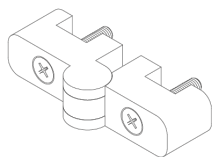

# THRESHOLD FIXING

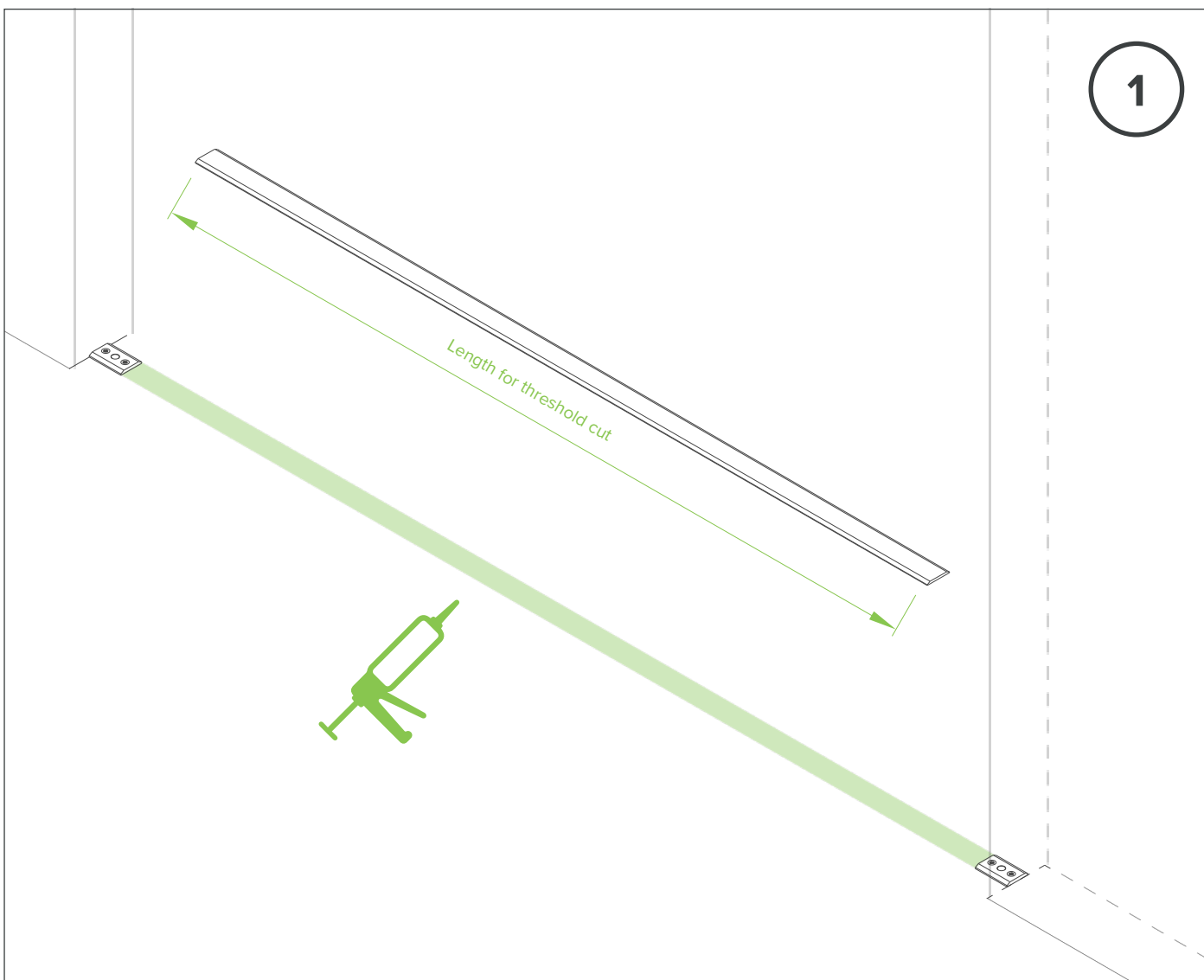
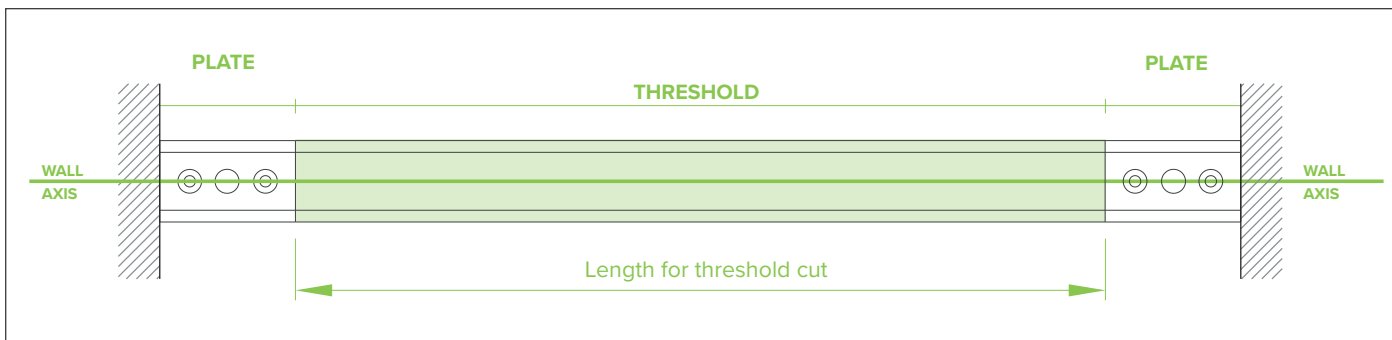

BEFORE PLACING THE THRESHOLD, SPREAD A LAYER OF SILICONE ON THE UNDERSIDE

## HOLES FOR PIN ON THRESHOLD

**!!! WARNING !!!**

Wait at least 12 hours before proceeding with the following steps.

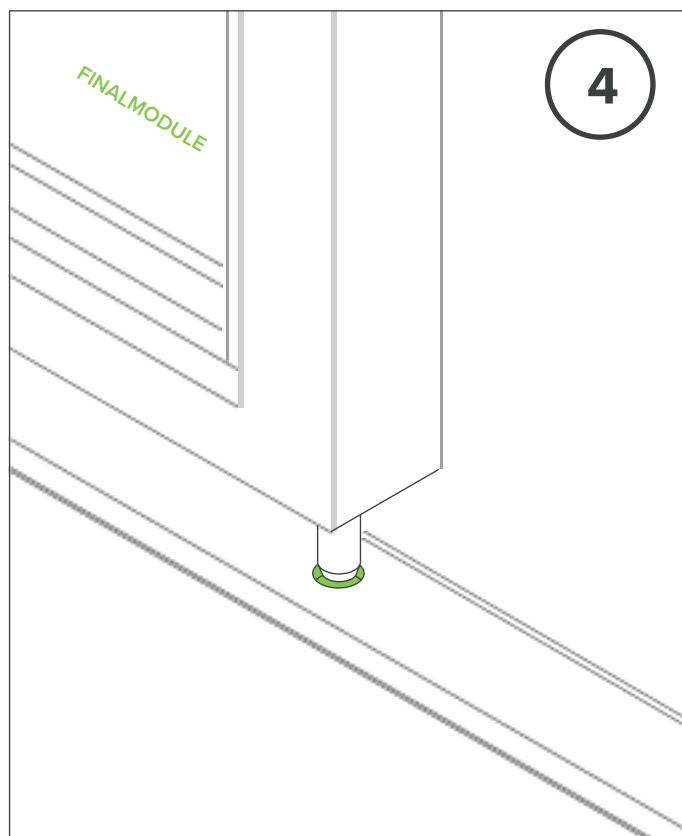
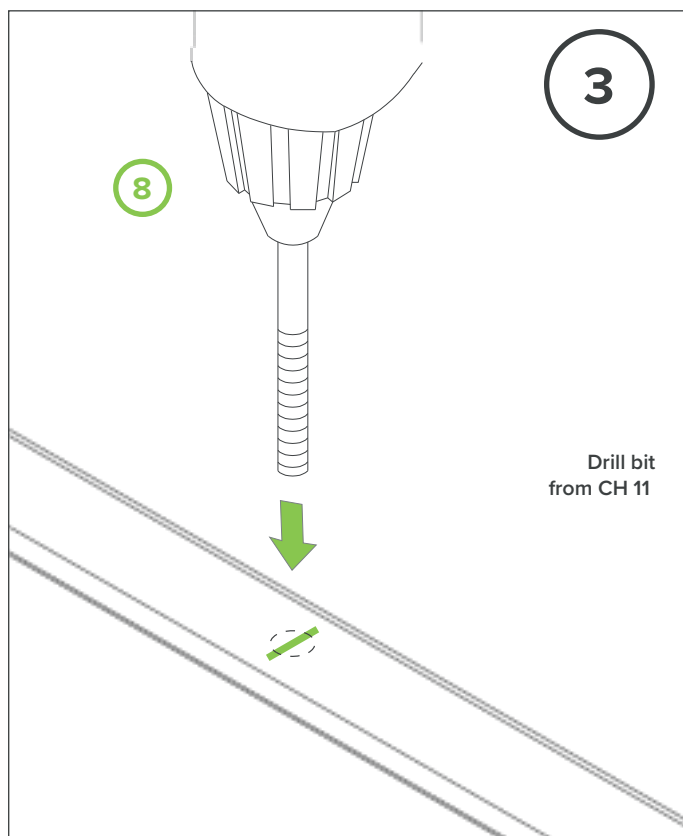
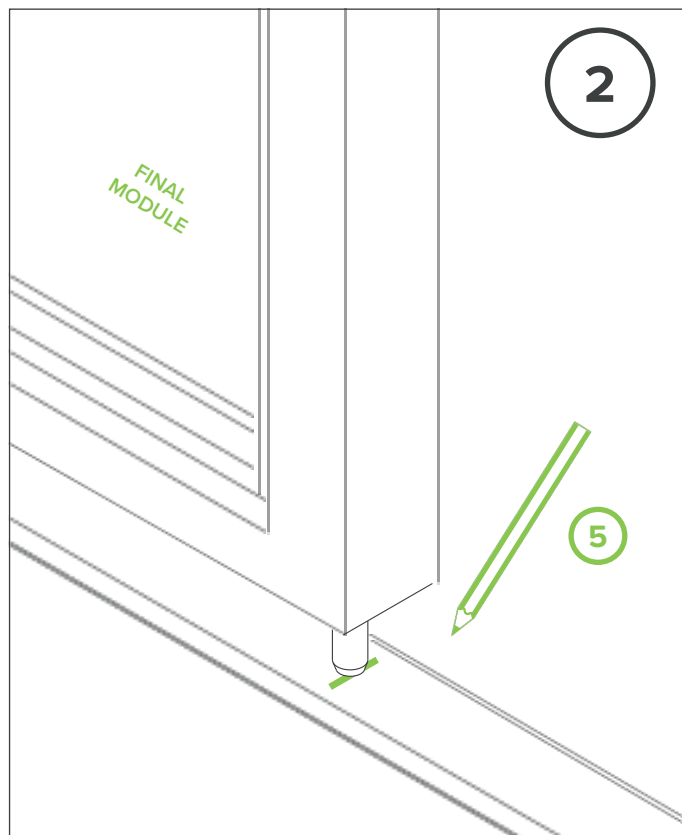
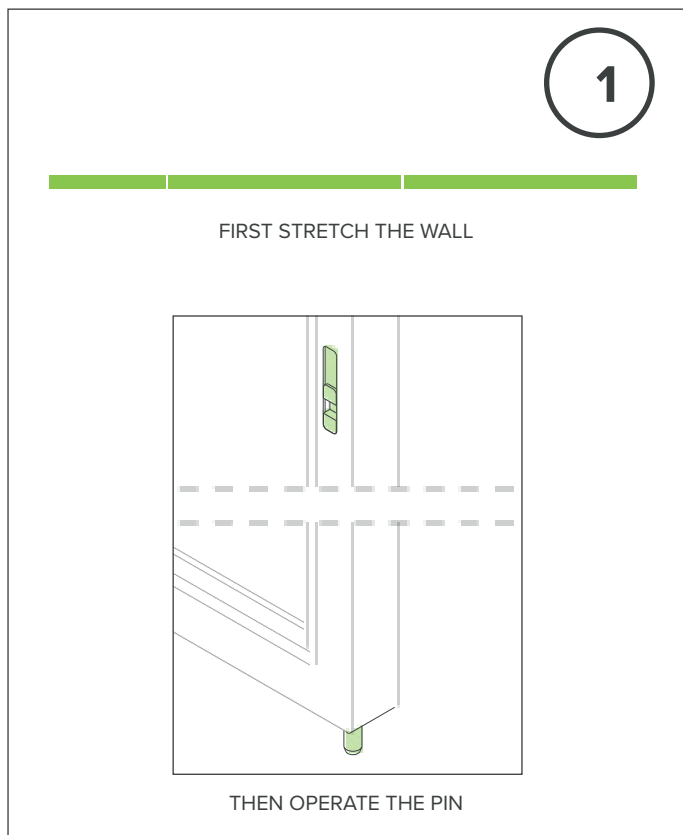

## RAIL LUBRICATION

Apply Vaseline at points about one meter apart.  
Then by operating the wall, the trolleys will distribute the lubricant within the entire rail.

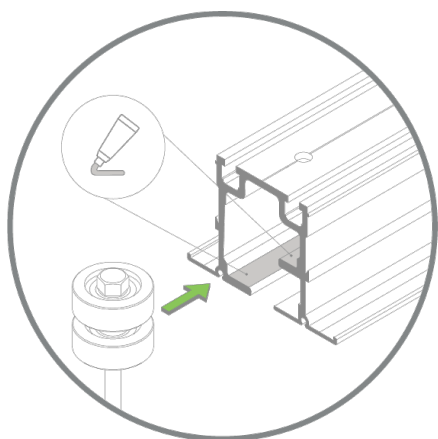
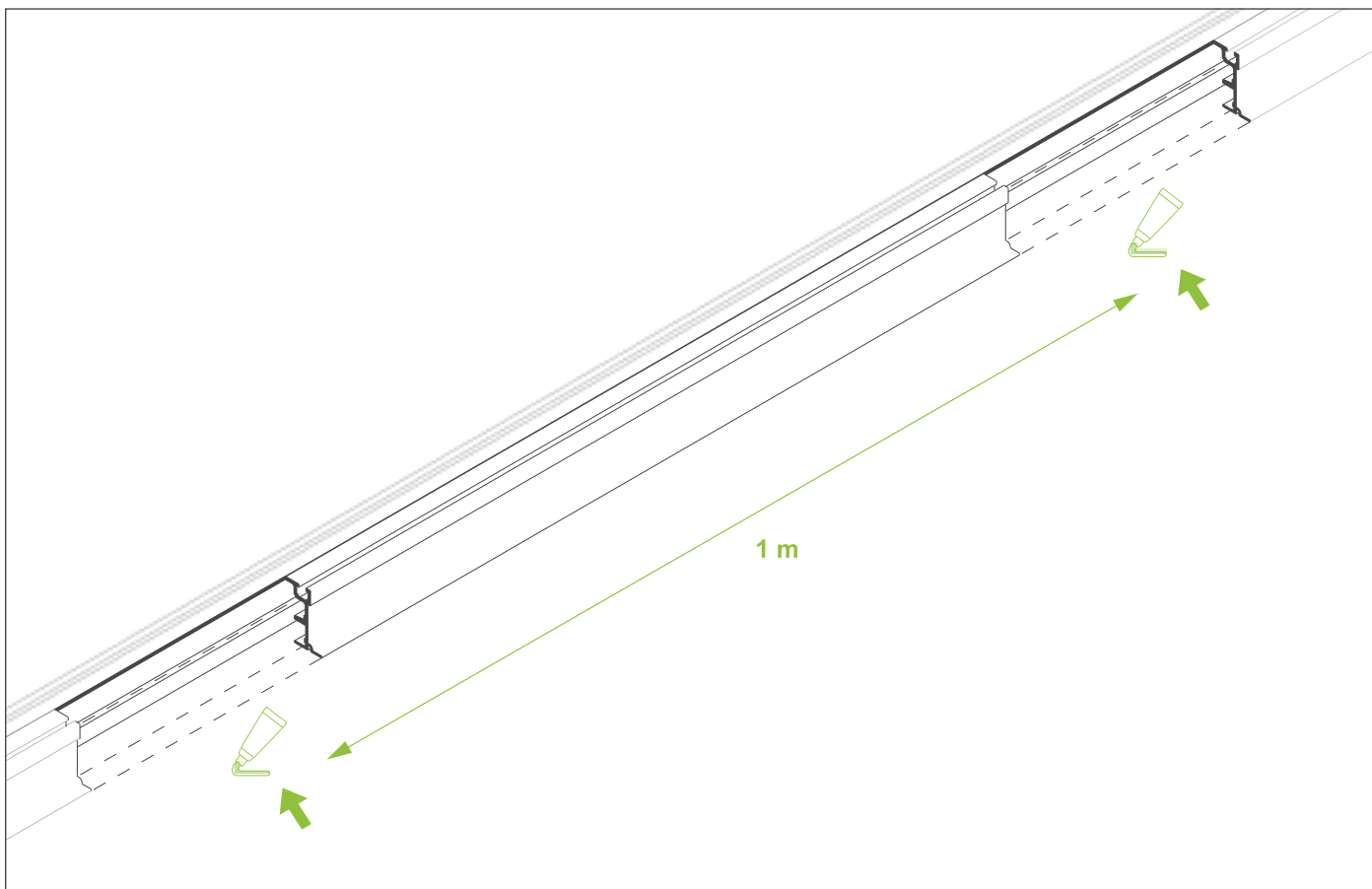

Rail flaps where to spread the Vaseline

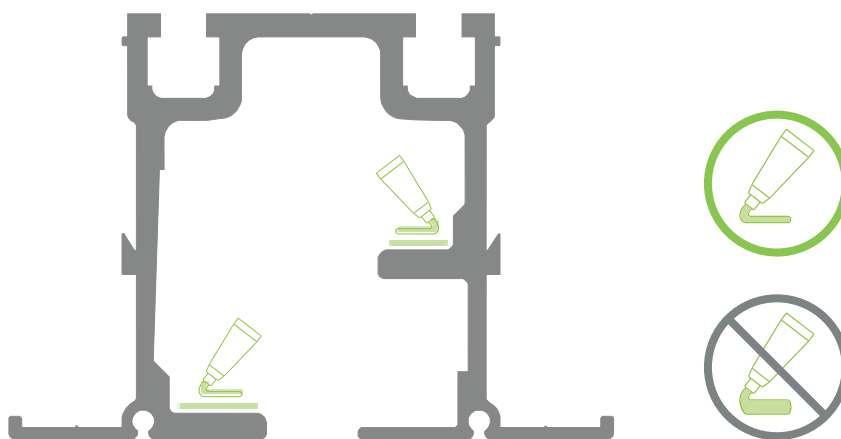

Section of the slide rail  
Where to spread the light layer of Vaseline

## USE AND MAINTENANCE

Before using the wall, read the manual carefully and keep it.  
Modules should be handled in the correct sequence.

### COMMERCIAL NAME

**AURA ZIP the glass aluminum folding partition**  
typology: folding sliding wall

### MATERIALS USED

#### Description

Folding sliding wall consisting of modules hinged to each other, composed of at least two modules, one of which is always anchored to the slide rail and to the floor; with slide rail only on the ceiling.

#### Frame

Aluminum frame, anodized 10-micron thick, powder-coated or liquid-coated according to the chosen color.

#### Glass

Laminated glass 44.1.

#### Panel

Chipboard panel, 16 mm thick, density 720 kg/sqm, CE, Fire Resistance Class B-s1, d0, Formaldehyde Emission Class E1, VOC free, inserted into the aluminum frame.

#### Slide rails

The rails are ceiling-mounted only and are made of aluminum painted white RAL 9010 20/30 Gloss.

### FINISHES

#### Frame

- Silver or champagne oxidized aluminum
- Painted RAL matte or metallic
- Painted in any RAL or NCS color

#### Glass

Float, extra-clear, satin-finished white, milk white, colored PVB, bronze, acid-etched bronze, reflective bronze, smoked, acid-etched smoked, reflective smoked, flute, fabric or wire mesh laminated glass.

#### Panel

- Covered in CPL White, Ivory, Gray
- HPL Colours series
- HPL wood veneer series
- Coated in laminate Polaris series
- HPL coated in Blackboard series
- Covered in HPL magnetic and writable
- Lacquered coating 20/30 gloss

#### Components

Burnished steel  
Niploy

### PRECAUTIONS FOR USE

Avoid improper and inappropriate uses of the product. Any tampering or installation not in accordance with the manufacturer's instructions could compromise product compliance.

### CLEANING AND MAINTENANCE

For perfect maintenance and operation of the product, it is necessary to properly clean the maneuverable wall. Since this is a furniture complement, we recommend the use of products for the home environment, specific to the finishes.

#### SLIDE RAIL

To clean the rail, use products specifically for aluminum. To maintain perfect sliding of the modules, it is advisable to put a light coat of Vaseline on the two fins of the rail, at least once a year.

#### PROFILES

When cleaning aluminum profiles, use products specifically for aluminum. Do not use solvents or abrasive pastes as they may cause them to lose their shine or be irreparably damaged. Aluminum profiles should not be subjected to shocks or blows: incorrect use of the maneuverable wall can cause aluminum profiles to deform, reducing their handling performance.

#### PANELS

For cleaning CPL and HPL surfaces, use furniture-specific neutral products, while for veneer use wood-specific neutral products. For lacquered surfaces, use clean, dry cloths. Infill panels should remain away from moisture.

#### GLASSES

Use glass-specific products to clean glass, and it is important to keep glass dry at all times.

(a) Handling from storage area to lying wall

1. Stand in front of the packed wall, hug the package and slide the modules.
2. To complete the handling, press on the fold of the profiles without visible hinges or press on the outer profile of the final module.

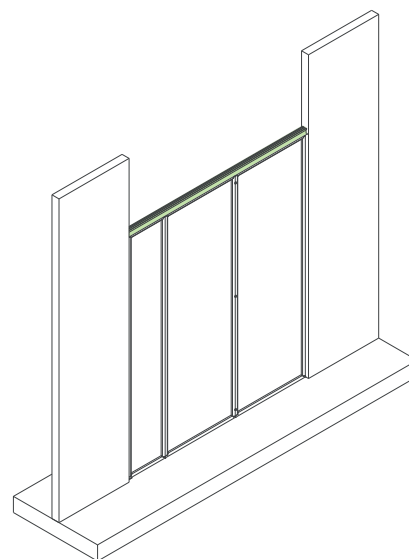
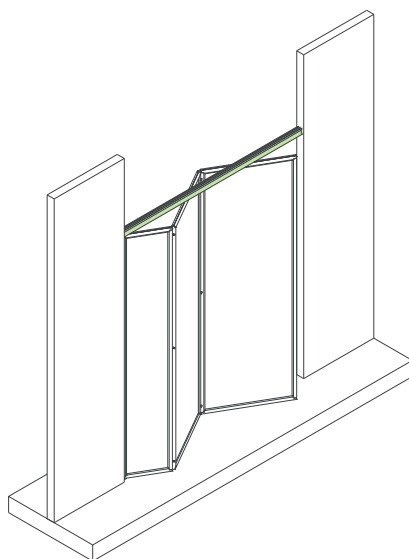
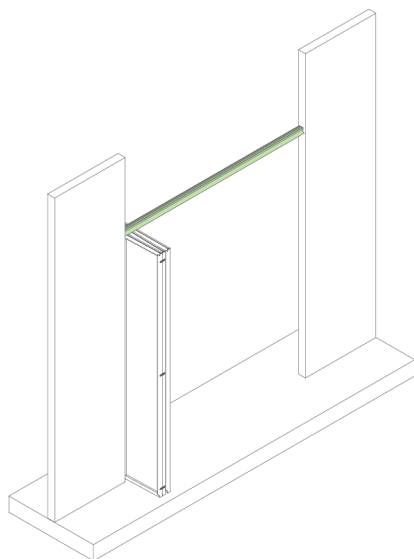

(b) Movement from lying wall to storage area

1. Stand facing the wall, depending on which side you are on, push on the center hinge.
2. Partially folded the wall, stand frontally and push the wall toward the storage area until the modules touch each other.

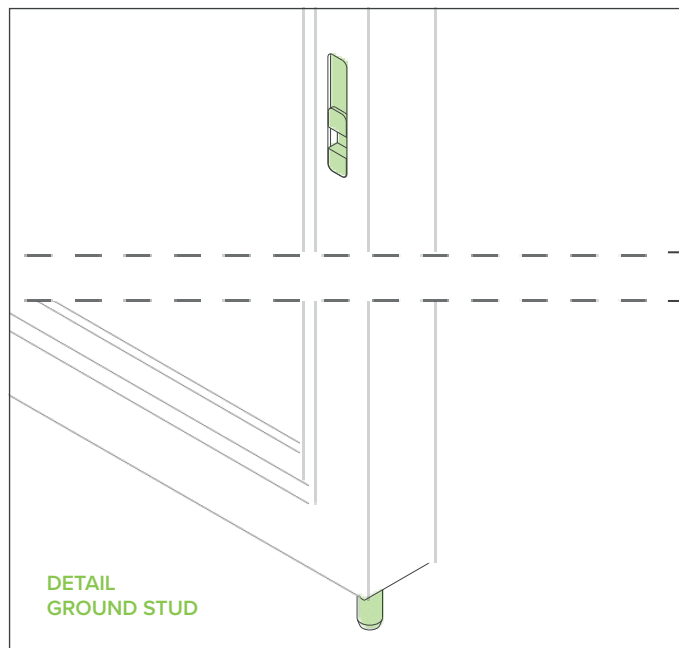
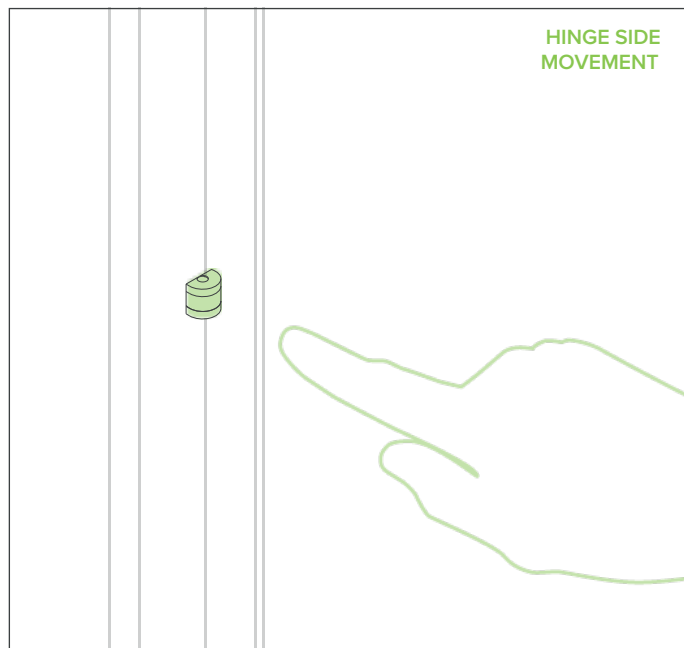

## **INSTALLATION, USE AND MAINTENANCE MANUAL - AURA ZIP**

### **EN**

This document is protected by copyright and intended exclusively for internal use. It is prohibited to make this document available to third parties, to reproduce it by any method or in any form - including extracts - and/or to utilise or communicate the content for any purpose other than internal use without the written consent of CARVART.

**CARVART®**

1441 Broadway floor 28,  
New York, NY 10018

(212) 675-0030

[www.carvart.com](http://www.carvart.com)  
[info@carvart.com](mailto:info@carvart.com)

Follow us on

