

chpIBOX
CB-CBOX-F

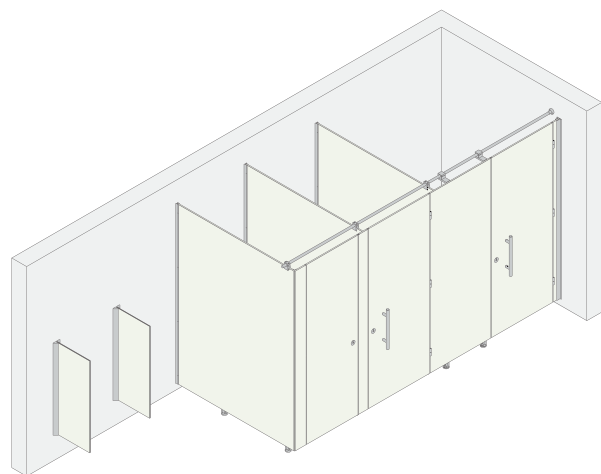

3D ISOMETRIC VIEW

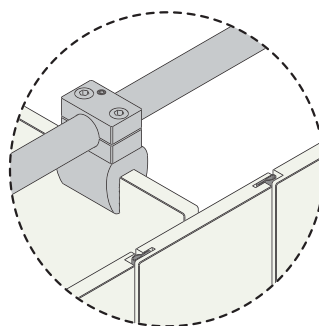

STABILIZING BAR DETAIL

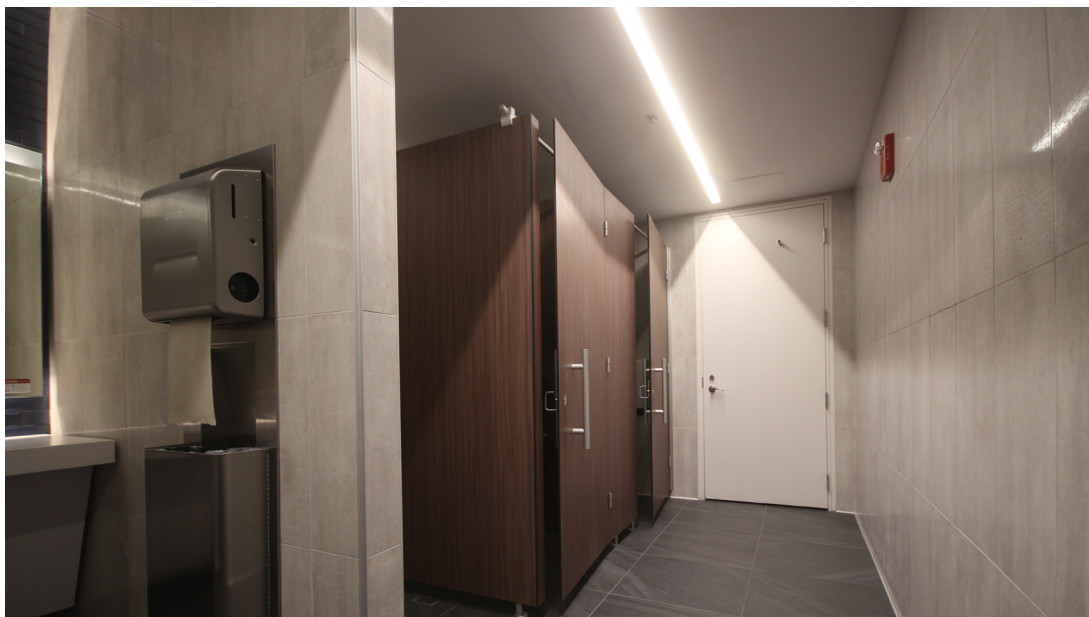

Specifications

chpIBOX

Similar to the glassBOX, the chpIBOX has a top stabilizing bar that holds the cubicles in place. The unique **CHPL (high-pressure phenolic laminate)** material facilitates a greater level of privacy, as panels are more easily shaped to conceal gaps and hardware connections.

APPLICATIONS —

Commercial bathroom cubicles and/or shower enclosures in airports, offices, entertainment venues, sports clubs/ facilities, gyms/spas, administrative buildings, hospitality.

HARDWARE —

- Double anodized aluminum with steel components (locks, fasteners, etc.)
- Self-closing, gravity hinges
- Top aluminum stabilizing bar
- Double anodized aluminum legs and channels

HARDWARE FINISHES —

- MFSA (satin anodized aluminum)
- MFBR (Brilliant aluminum)
- MFTI (Titanium finished aluminum)

HEIGHT (OVERALL MAXIMUM) —

Standard Height: 87-3/4"

MOUNTING OPTIONS —

- Cubicle fastens to side walls
- Anchored to finished flooring
- Does not fasten to ceiling; cubicle can span full height of room or can be dropped down to allow for sprinklers, ventilation, etc.

CHPL THICKNESS —

-Accommodates 9/16" [14mm] Nominal

WARRANTY —

1 Year Limited Warranty

Specification Code: **CB-CBOX-F**

CB	CBOX	F
LINE	TYPE	MODEL/ID