

# Workstations > LEVEL

(GS-SW-L)

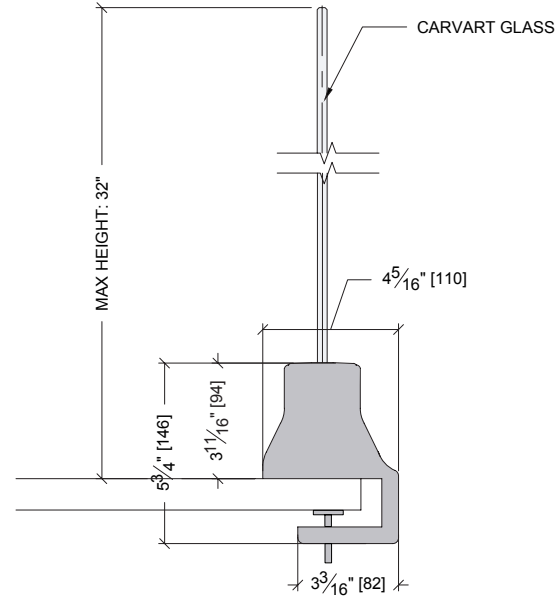

TYPICAL DETAILS

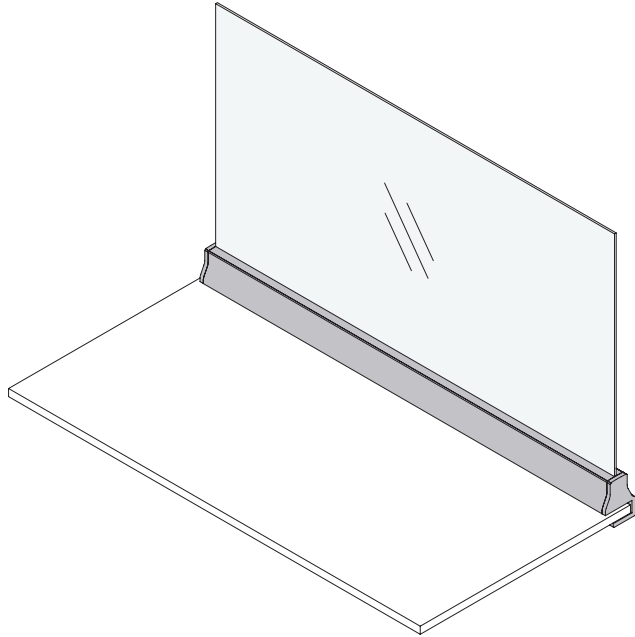
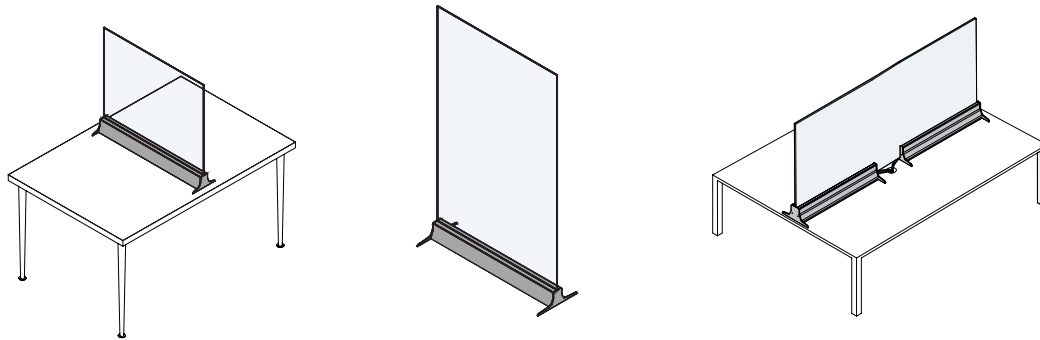

EXAMPLE CONFIGURATIONS

## Specifications

### Workstations>LEVEL

CARVART's benching screens offer a timeless architectural design that are flexible and adaptable, while providing hygienic protection for our ever-changing workplace. The sleek aesthetics blend into any space and are ideal for protection and engagement with non-porous, scratch resistant tempered glass that is increasingly durable, ensuring a greater product longevity.

#### APPLICATIONS —

Space division between working areas

#### HARDWARE MATERIALS/FINISHES —

Satin Anodized

#### PANEL WIDTHS (OVERALL MAXIMUM)—

Inquire for layout options

#### PANEL HEIGHTS —

Max Height: 32"

#### MOUNTING OPTIONS —

Clamp, Mechanically Fastened

#### MAX TABLE THICKNESS —

1-1/4"

#### GLASS THICKNESSES —

1/4" - 1/2"

#### WARRANTY —

1 Year Limited Warranty

Specification Code: **GS-SW-L**

<b>GS</b>	<b>SW</b>	<b>L</b>
LINE	TYPE	MODEL/ID